

# ALUMINUM ELECTROLYTIC CAPACITORS

**NK** series Screw Terminal Type, 85°C Smaller-sized

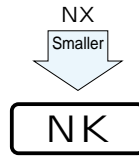

- Load life 5000 hours application of ripple current at 85°C.
- Compliant to the RoHS directive (2002/95/EC).



## Specifications

Item	Performance Characteristics	
Category Temperature Range	- 25 to +85°C	
Rated Voltage Range	350 to 500V	
Rated Capacitance Range	1000 to 18000μF	
Capacitance Tolerance	±20% at 120Hz, 20°C	
Leakage Current	After 5 minutes' application of rated voltage, leakage current is not more than $3\sqrt{CV}$ (μA) or 5 mA, whichever is smaller (at 20°C). [C : Rated Capacitance(μF), V : Voltage (V)]	
Tangent of loss angle (tan δ)	0.20MAX. (120Hz, 20°C)	
Stability at Low Temperature	Rated voltage (V)	350 to 500
	Impedance ratio ZT/Z20(MAX.)	Z - 25°C / Z+20°C 8
Measurement frequency : 120Hz		
Insulation Resistance	The insulation resistance shall be more than 100MΩ at DC 500V application between terminal and bracket.	
Voltage proof	There is no abnormality during AC 2500V 1 minute's application between terminal and bracket.	
Endurance	The specifications listed at right shall be met when the capacitors are restored to 20°C after D.C. bias plus rated ripple current is applied for 5000 hours at 85°C, the peak voltage shall not exceed the rated voltage.	
	Capacitance change	Within ±20% of the initial capacitance value
	tan δ	300% or less than the initial specified value
Shelf Life	After storing the capacitors under no load at 85°C for 1000 hours and then performing voltage treatment based on JIS C 5101-4 clause 4.1 at 20°C, they shall meet the specified value for endurance characteristics listed at light.	
	Capacitance change	Within ±20% of the initial capacitance value
	tan δ	300% or less than the initial specified value
Marking	Printed with white color letter on black sleeve.	
	Leakage current	Less than or equal to the initial specified value

## Drawing

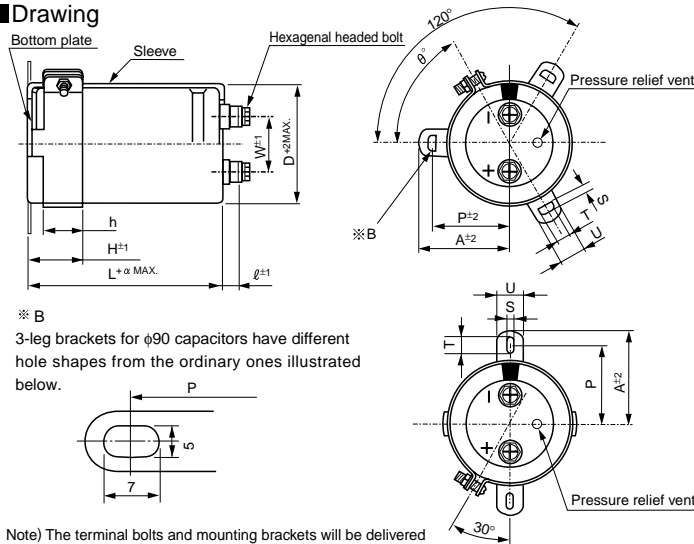

※ B  
3-leg brackets for φ90 capacitors have different hole shapes from the ordinary ones illustrated below.

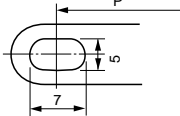

Note) The terminal bolts and mounting brackets will be delivered

- Estimated life time of capacitor is calculated by the following formula, taking the operating temperature, inner temperature rise due to the ripple and derated voltage into consideration.

$$Ln = L_0 \times 2^{\frac{85-T}{10}} \times 2^{-\frac{\Delta T}{K}} \times \alpha$$

Where,  
 Ln : Lifetime under normal operating conditions.(h)  
 L0 : Lifetime under maximum operating temperature of 85°C and applied DC voltage. (28000h)  
 T : Ambient temperature.(°C)  
 ΔT : Inner temperature rise of capacitor due to ripple current(°C)  
 K : Acceleration coefficient for temperature rise due to the ripple current.  
 when T+ΔT ≤ 90°C, K=10  
 when T+ΔT > 90°C, K=2.5  
 α : Life factor

- Life factor α due to the voltage derating shall be decided by the temperature and the applied voltage

Oper. temp.	T ≤ 70°C	70°C < T ≤ 85°C		
Voltage ratio	—	V/Vo ≤ 0.8	0.8 < V/Vo ≤ 0.9	0.9 < V/Vo ≤ 1.0
α	1.0	1.0	0.8	0.7

V : Applied voltage(V) Vo : Rated voltage(V)

## Frequency coefficient of rated ripple current

Frequency (Hz)	50	60	120	360	1k	10k or more
Coefficient	0.80	0.82	1.00	1.20	1.35	1.40

- Please contact us about estimated life of more than 500V.
- Flame-retardant type electrolyte is also available.
- Please contact to Nichicon representative for the rated ripple current value.

## Type numbering system (Example : 400V 10000μF)

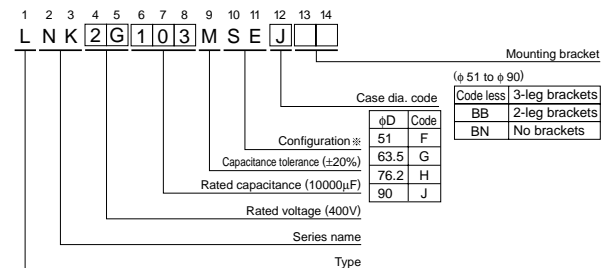

### Configuration

Cr(III) Plating  
(RoHS compliant)  
SE

※ Please contact to us if PVCless products are required.

## Dimension of terminal pitch (W) and length (ℓ) and Nominal dia. of bolt (mm)

φD	W	ℓ	α	Nominal dia. of bolt
51	22.0	6	3	M 5
63.5	28.6	6	3	M 5
76.2	31.8	6	3	M 5
90	31.8	6	3	M 5

## Dimensions of mounting bracket (mm)

Symbol	3-Leg		2-Leg					
	51	63.5	76.2	90	51	63.5	76.2	90
P	32.5	38.1	44.5	50.8	33.2	40.5	46.5	53
A	38.5	43	49.2	58.5	40	46.5	53	59
T	7.5	8.0	7.0	8.0	6.0	7.0	6.0	6.0
S	5.0	5.0	5.0	5.0	4.5	4.5	4.5	4.5
U	12	14	14	18	14	14	14	14
θ°	60	60	60	60	30	30	30	30
H	20	25	30	35	25	35	35	35
h	15	20	24	25	15	20	20	20

- Dimension table in next page.

## ■ Dimensions

350V (2V)					
Cap. (μF)	Size φD × L(mm)	Rated ripple (Arms)	tan δ	Leakage Current (mA)	Code
1000	51 × 60	4.8	0.20	1.77	LNK2V102MSEF
1200	51 × 70	5.5	0.20	1.94	LNK2V122MSEF
1500	51 × 75	6.5	0.20	2.17	LNK2V152MSEF
1800	51 × 90	7.3	0.20	2.38	LNK2V182MSEF
2200	51 × 95	8.2	0.20	2.63	LNK2V222MSEF
2700	51 × 105	9.3	0.20	2.91	LNK2V272MSEF
	63.5 × 85	9.9	0.20	2.91	LNK2V272MSEG
3300	63.5 × 95	11.8	0.20	3.22	LNK2V332MSEG
3900	63.5 × 100	12.8	0.20	3.50	LNK2V392MSEG
	76.2 × 85	13.0	0.20	3.50	LNK2V392MSEH
4700	63.5 × 115	13.8	0.20	3.84	LNK2V472MSEG
	76.2 × 90	14.2	0.20	3.84	LNK2V472MSEH
5600	63.5 × 130	17.3	0.20	4.20	LNK2V562MSEG
	76.2 × 100	16.8	0.20	4.20	LNK2V562MSEH
6800	63.5 × 155	19.6	0.20	4.62	LNK2V682MSEG
	76.2 × 115	19.0	0.20	4.62	LNK2V682MSEH
8200	63.5 × 190	22.6	0.20	5.00	LNK2V822MSEG
	76.2 × 130	21.0	0.20	5.00	LNK2V822MSEH
	90 × 120	24.0	0.20	5.00	LNK2V822MSEJ
10000	76.2 × 155	25.1	0.20	5.00	LNK2V103MSEH
	90 × 140	25.9	0.20	5.00	LNK2V103MSEJ
12000	90 × 150	28.4	0.20	5.00	LNK2V123MSEJ

400V (2G)					
Cap. (μF)	Size φD × L(mm)	Rated ripple (Arms)	tan δ	Leakage Current (mA)	Code
1000	51 × 65	5.0	0.20	1.89	LNK2G102MSEF
1200	51 × 75	5.8	0.20	2.07	LNK2G122MSEF
1500	51 × 90	6.8	0.20	2.32	LNK2G152MSEF
1800	51 × 95	7.3	0.20	2.54	LNK2G182MSEF
2200	51 × 105	8.8	0.20	2.81	LNK2G222MSEF
	63.5 × 85	8.9	0.20	2.81	LNK2G222MSEG
2700	51 × 115	10.2	0.20	3.11	LNK2G272MSEF
	63.5 × 90	10.8	0.20	3.11	LNK2G272MSEG
	76.2 × 75	10.6	0.20	3.11	LNK2G272MSEH
3300	63.5 × 95	11.8	0.20	3.44	LNK2G332MSEG
	76.2 × 90	12.0	0.20	3.44	LNK2G332MSEH
3900	63.5 × 115	12.8	0.20	3.74	LNK2G392MSEG
	76.2 × 95	13.0	0.20	3.74	LNK2G392MSEH
4700	63.5 × 130	14.8	0.20	4.11	LNK2G472MSEG
	76.2 × 110	15.0	0.20	4.11	LNK2G472MSEH
5600	63.5 × 155	17.0	0.20	4.49	LNK2G562MSEG
	76.2 × 115	16.5	0.20	4.49	LNK2G562MSEH
6800	63.5 × 190	20.6	0.20	4.94	LNK2G682MSEG
	76.2 × 130	19.2	0.20	4.94	LNK2G682MSEH
	90 × 120	20.7	0.20	4.94	LNK2G682MSEJ
8200	76.2 × 155	22.7	0.20	5.00	LNK2G822MSEH
	90 × 120	22.9	0.20	5.00	LNK2G822MSEJ
10000	76.2 × 170	26.2	0.20	5.00	LNK2G103MSEH
	90 × 130	24.2	0.20	5.00	LNK2G103MSEJ
12000	90 × 155	28.5	0.20	5.00	LNK2G123MSEJ
15000	90 × 190	34.8	0.20	5.00	LNK2G153MSEJ
18000	90 × 235	41.2	0.20	5.00	LNK2G183MSEJ

450V (2W)					
Cap. (μF)	Size φD × L(mm)	Rated ripple (Arms)	tan δ	Leakage Current (mA)	Code
1000	51 × 75	5.2	0.20	2.01	LNK2W102MSEF
1200	51 × 85	6.3	0.20	2.20	LNK2W122MSEF
1500	51 × 95	6.4	0.20	2.46	LNK2W152MSEF
1800	51 × 105	7.6	0.20	2.70	LNK2W182MSEF
	63.5 × 85	7.6	0.20	2.70	LNK2W182MSEG
2200	63.5 × 90	9.0	0.20	2.98	LNK2W222MSEG
	76.2 × 85	9.4	0.20	2.98	LNK2W222MSEH
2700	63.5 × 95	10.5	0.20	3.30	LNK2W272MSEG
	76.2 × 90	11.0	0.20	3.30	LNK2W272MSEH
3300	63.5 × 115	12.1	0.20	3.65	LNK2W332MSEG
	76.2 × 100	12.9	0.20	3.65	LNK2W332MSEH
3900	76.2 × 110	14.2	0.20	3.97	LNK2W392MSEH
4700	63.5 × 155	15.6	0.20	4.36	LNK2W472MSEG
	76.2 × 115	15.1	0.20	4.36	LNK2W472MSEH
5600	63.5 × 190	18.7	0.20	4.76	LNK2W562MSEG
	90 × 120	18.6	0.20	4.76	LNK2W562MSEJ
6800	76.2 × 155	20.7	0.20	5.00	LNK2W682MSEH
	90 × 125	20.0	0.20	5.00	LNK2W682MSEJ
8200	76.2 × 190	19.1	0.20	5.00	LNK2W822MSEH
12000	90 × 190	29.7	0.20	5.00	LNK2W123MSEJ
15000	90 × 235	35.9	0.20	5.00	LNK2W153MSEJ

500V (2H)					
Cap. (μF)	Size φD × L(mm)	Rated ripple (Arms)	tan δ	Leakage Current (mA)	Code
1000	51 × 100	4.2	0.20	2.12	LNK2H102MSEF
	63.5 × 80	4.2	0.20	2.12	LNK2H102MSEG
1200	51 × 115	6.2	0.20	2.32	LNK2H122MSEF
	63.5 × 85	6.3	0.20	2.32	LNK2H122MSEG
1500	51 × 130	7.3	0.20	2.59	LNK2H152MSEF
	63.5 × 90	7.1	0.20	2.59	LNK2H152MSEG
1800	63.5 × 105	8.3	0.20	2.84	LNK2H182MSEG
2200	63.5 × 120	9.6	0.20	3.14	LNK2H222MSEG
2700	76.2 × 110	10.7	0.20	3.48	LNK2H272MSEH
3300	76.2 × 115	12.4	0.20	3.85	LNK2H332MSEH
3900	76.2 × 150	14.4	0.20	4.18	LNK2H392MSEH
	90 × 120	14.4	0.20	4.18	LNK2H392MSEJ
4700	76.2 × 170	16.5	0.20	4.59	LNK2H472MSEH
	90 × 130	15.8	0.20	4.59	LNK2H472MSEJ
5600	76.2 × 190	19.0	0.20	5.00	LNK2H562MSEH
	90 × 150	18.6	0.20	5.00	LNK2H562MSEJ
6800	90 × 170	21.2	0.20	5.00	LNK2H682MSEJ
8200	90 × 190	24.5	0.20	5.00	LNK2H822MSEJ
10000	90 × 235	29.3	0.20	5.00	LNK2H103MSEJ

Rated ripple current (Arms) at 85°C 120Hz