

LS series Radial Lead Type, Long Life Assurance

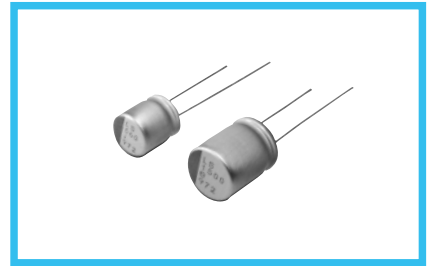

- Ultra-low ESR, High ripple current.
- Load life of 5000 hours at 105°C.
- Radial lead type :
Lead free flow soldering condition correspondence.
- Compliant to the RoHS directive (2002/95/EC).



■ Specifications

Item	Performance Characteristics		
Category Temperature Range	-55 to +105°C		
Rated Voltage Range	2.5 to 16V		
Rated Capacitance Range	100 to 1500μF		
Capacitance Tolerance	±20% at 120Hz, 20°C		
Tangent of loss angle (tan δ)	Less than or equal to the specified value at 120Hz, 20°C		
ESR (※ 1)	Less than or equal to the specified value at 100kHz, 20°C		
Leakage Current (※ 2)	Less than or equal to the specified value. After 2 minutes' application of rated voltage at 20°C		
Temperature Characteristics (Max.Impedance Ratio)	Z+105°C / Z+20°C ≤ 1.25 (100kHz) Z-55°C / Z+20°C ≤ 1.25		
Endurance	The specifications listed at right shall be met when the capacitors are restored to 20°C after the rated voltage is applied for 5000 hours at 105°C.	Capacitance change	Within ± 20% of the initial capacitance value (※ 3)
		tan δ	150% or less than the initial specified value
		ESR (※ 1)	150% or less than the initial specified value
		Leakage current (※ 2)	Less than or equal to the initial specified value
Damp Heat (Steady State)	The specifications listed at right shall be met when the capacitors are restored to 20°C after the rated voltage is applied for 1000 hours at 60°C, 90% RH.	Capacitance change	Within ± 20% of the initial capacitance value (※ 3)
		tan δ	150% or less than the initial specified value
		ESR (※ 1)	150% or less than the initial specified value
		Leakage current (※ 2)	Less than or equal to the initial specified value
Resistance to Soldering Heat	After soldering the capacitor under the soldering conditions prescribed here as preheat at 150 to 200°C for 60 to 180 seconds and peak temperature at 265°C for 10 seconds or less, the capacitor shall meet the specifications listed at right, provided that its temperature profile is measured at both of terminal ends facing the soldering side.	Capacitance change	Within ± 10% of the initial capacitance value (※ 3)
		tan δ	130% or less than the initial specified value
		ESR (※ 1)	130% or less than the initial specified value
		Leakage current (※ 2)	Less than or equal to the initial specified value
Marking	Navy blue print on the case top		

- ※ 1 ESR should be measured at both of the terminal ends closest to the capacitor body.
- ※ 2 Conditioning : If any doubt arises, measure the leakage current after the voltage treatment of applying DC rated voltage continuously to the capacitor for 120 minutes at 105°C.
- ※ 3 Initial value : The value before test of examination of resistance to soldering.

■ Dimensions

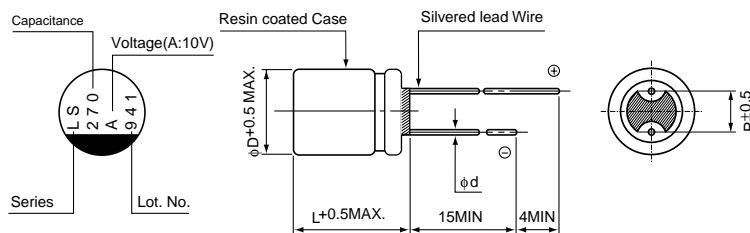

Type numbering system (Example : 10V 270μF)

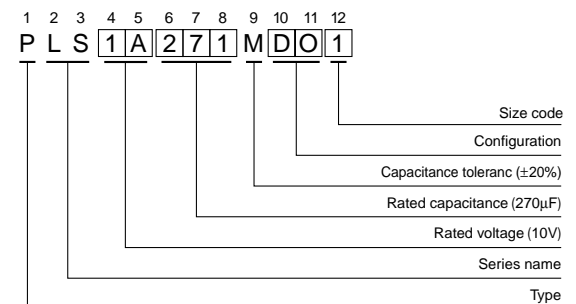

(mm)

Size	φ6.3 × 9L	φ6.3 × 10.5L	φ8 × 7L	φ8 × 9L	φ8 × 12L	φ10 × 13L
φD	6.3	6.3	8.0	8.0	8.0	10.0
L	8.5	10.0	6.5	8.5	11.5	12.5
P	2.5	2.5	3.5	3.5	3.5	5.0
φd	0.6	0.5	0.6	0.6	0.6	0.6

Voltage	V	2.5	4	6.3	10	16
Code	e	g	j	A	C	

Please refer to page 20 about the end seal configuration.

● Dimension table in next page.



■ Standard Ratings

Rated Voltage (V) code	Surge Voltage (V)	Rated Capacitance (μF)	Case Size φD × L (mm)	tan δ	Leakage Current (μA)	ESR (mΩ) (at 100kHz 20°C)	Rated Ripple (mAmps)	Part Number
2.5 (0E)	2.8	330	○ 6.3 × 9	0.08	500	8	4800	PLS0E331MCO8
		680	△ 8 × 7	0.08	340	15	3900	PLS0E681MCL2
		820	○ 6.3 × 9	0.08	500	8	4800	PLS0E821MCO8
		820	▲ 8 × 9	0.08	410	7	5200	PLS0E821MCO6
		820	8 × 12	0.08	410	7	5800	PLS0E821MDO1
		1500	10 × 13	0.08	750	8	5500	PLS0E152MDO1
4 (0G)	4.6	270	○ 6.3 × 9	0.08	500	8	4800	PLS0G271MCO8
		560	△ 8 × 7	0.08	448	15	3900	PLS0G561MCL2
		560	▲ 8 × 9	0.08	448	7	5200	PLS0G561MCO6
		680	8 × 12	0.08	544	7	5800	PLS0G681MDO1
		1200	10 × 13	0.08	960	8	5500	PLS0G122MDO1
6.3 (0J)	7.2	330	■ 6.3 × 10.5	0.08	416	20	3000	PLS0J331MDL4
		390	△ 8 × 7	0.08	491	15	3900	PLS0J391MCL2
		470	8 × 12	0.08	592	7	5500	PLS0J471MDO1
		560	○ 6.3 × 9	0.08	706	9	4300	PLS0J561MCO8
		560	▲ 8 × 9	0.08	706	8	5000	PLS0J561MCO6
		820	10 × 13	0.08	1033	8	5500	PLS0J821MDO1
10 (1A)	11.5	150	■ 6.3 × 10.5	0.08	300	20	3000	PLS1A151MDL4
		270	8 × 12	0.08	540	8	4900	PLS1A271MDO1
		470	10 × 13	0.08	940	8	5500	PLS1A471MDO1
16 (1C)	18.4	100	■ 6.3 × 10.5	0.08	320	24	2800	PLS1C101MDL4
		270	8 × 12	0.08	864	9	4500	PLS1C271MDO1
		330	10 × 13	0.08	1056	9	4700	PLS1C331MDO1
		470	10 × 13	0.08	1504	9	4700	PLS1C471MDO1

Rated ripple current (mAmps) at 105°C 100kHz

No marked, [1] will be put at 12th digit of type numbering system.
 △ : In this case, [2] will be put at 12th digit of type numbering system.
 ■ : In this case, [4] will be put at 12th digit of type numbering system.
 ▲ : In this case, [6] will be put at 12th digit of type numbering system.
 ○ : In this case, [8] will be put at 12th digit of type numbering system.

- Taping specifications are given in page 20, 21, 22.
- Please refer to page 3 for the minimum order quantity.