

RPS / RPA Standard (φ6.3, φ8, φ10)

FPCAP

- High voltage (to 63V), Low ESR, High ripple current.
- Load life of 2000 / 5000 hours at 105°C.
- SMD type : Lead free reflow soldering condition at 260°C peak correspondence.
- Compliant to the RoHS directive (2011/65/EU,(EU)2015/863).

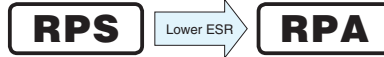

Specifications

Item	Performance Characteristics	
Category Temperature Range	-55 to +105°C	
Rated Voltage Range	2.5 to 63V	
Rated Capacitance Range	8.2 to 1500μF	
Capacitance Tolerance	±20% at 120Hz, 20°C	
Tangent of loss angle (tan δ)	Less than or equal to the specified value at 120Hz, 20°C	
ESR (※1)	Less than or equal to the specified value at 100kHz, 20°C	
Leakage Current (※2)	Less than or equal to the specified value. After 2 minutes' application of rated voltage at 20°C	
Endurance	Test condition	105°C, rated voltage 2000 / 5000Hrs.
	Capacitance change	Within ±20% of initial value before test
	tan δ	150% or less than the initial specified value
	ESR(※1)	150% or less than the initial specified value
	Leakage current (※2)	Less than or equal to the initial specified value

※1 ESR should be measured at both of the terminal ends closest where the terminals protrude through the plastic platform.

※2 Conditioning : If any doubt arises, measure the leakage current after the voltage treatment of applying DC rated voltage continuously to the capacitor for 120 minutes at 105°C.

Dimensions

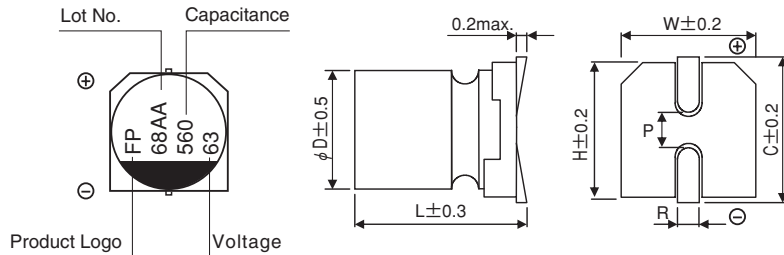

φD×L	W	H	C	R	P
6.3×5.7	6.5	6.5	7.2	0.5 to 0.9	2.1
8×6.7	8.3	8.3	9.0	0.8 to 1.1	3.2
8×11.7	8.3	8.3	9.0	0.8 to 1.1	3.2
10×7.7	10.3	10.3	11.0	0.8 to 1.1	4.6
10×12.4	10.3	10.3	11.0	0.8 to 1.1	4.6

Frequency coefficient of rated ripple current

Frequency	120 Hz	1 kHz	10 kHz	100 kHz	300 kHz
Coefficient	0.10	0.45	0.50	1.00	1.00

Type numbering system (Example : 63V 56μF)

Nichicon part number

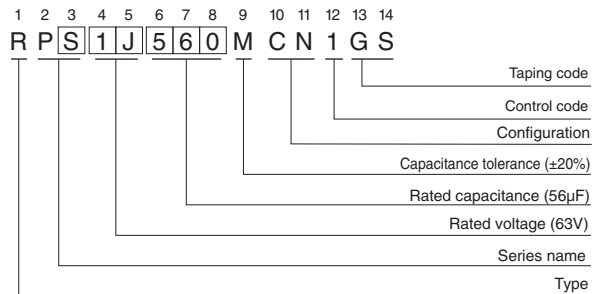

FPCAP part number

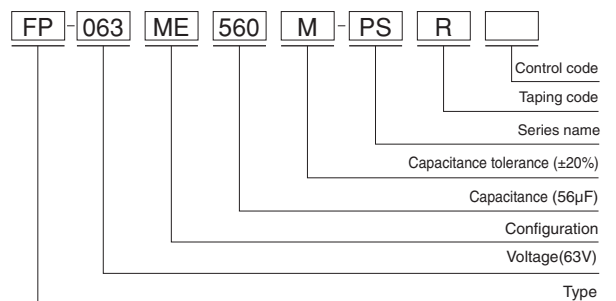

● Dimension table in next page.

RPS / RPA

■ Dimensions

Rated Voltage (V) (code)	Surge Voltage (V)	Rated Capacitance (μF)	Case Size φD×L (mm)	tan δ	Leakage Current (μA) (at 20°C after 2 minutes)	ESR (mΩ) (20°C/100kHz)	Rated Ripple Current (mA rms) (105°C/100kHz)	NICHICON	FPCAP		
2.5 (0E)	2.8	680	8×11.7	0.12	425	13	4500	RPS0E681MCN1GS	FP-2R5ME681M-PSR		
		1500	10×12.4	0.12	937	10	5500	RPS0E152MCN1GS	FP-2R5ME152M-PSR		
4.0 (0G)	4.6	100	6.3×5.7	0.12	80	35	2200	RPS0G101MCN1GS	FP-4R0ME101M-PSR		
		220	8×6.7	0.12	176	30	2700	RPS0G221MCN1GS	FP-4R0ME221M-PSR		
		330	8×6.7	0.12	264	30	2700	RPS0G331MCN1GS	FP-4R0ME331M-PSR		
		470	10×7.7	0.12	376	22	3800	RPS0G471MCN1GS	FP-4R0ME471M-PSR		
		560	8×11.7	0.12	448	13	4500	RPS0G561MCN1GS	FP-4R0ME561M-PSR		
		560	8×11.7	0.12	448	9	5400	RPA0G561MCN1GS	FP-4R0ME561M-PAR		
		680	10×7.7	0.12	544	22	3800	RPS0G681MCN1GS	FP-4R0ME681M-PSR		
		1200	10×12.4	0.12	960	12	5500	RPS0G122MCN1GS	FP-4R0ME122M-PSR		
6.3 (0J)	7.2	82	6.3×5.7	0.12	103	35	2200	RPS0J820MCN1GS	FP-6R3ME820M-PSR		
		150	8×6.7	0.12	189	30	2600	RPS0J151MCN1GS	FP-6R3ME151M-PSR		
		180	8×6.7	0.12	226	30	2600	RPS0J181MCN1GS	FP-6R3ME181M-PSR		
		330	10×7.7	0.12	415	22	3600	RPS0J331MCN1GS	FP-6R3ME331M-PSR		
		470	8×11.7	0.15	592	15	4300	RPS0J471MCN1GS	FP-6R3ME471M-PSR		
		470	10×7.7	0.12	592	18	4300	RPA0J471MCN1GS	FP-6R3ME471M-PAR		
		560	8×11.7	0.15	705	14	4400	RPS0J561MCN1GS	FP-6R3ME561M-PSR		
		680	10×12.4	0.15	642	13	5200	RPS0J681MCN1GS	FP-6R3ME681M-PSR		
		820	10×12.4	0.15	774	12	5500	RPS0J821MCN1GS	FP-6R3ME821M-PSR		
		1000	10×12.4	0.15	945	12	5500	RPS0J102MCN1GS	FP-6R3ME102M-PSR		
10 (1A)	11.5	47	6.3×5.7	0.12	94	40	2100	RPS1A470MCN1GS	FP-010ME470M-PSR		
		56	6.3×5.7	0.12	112	40	2100	RPS1A560MCN1GS	FP-010ME560M-PSR		
		120	8×6.7	0.12	240	30	2600	RPS1A121MCN1GS	FP-010ME121M-PSR		
		270	10×7.7	0.12	540	25	3500	RPS1A271MCN1GS	FP-010ME271M-PSR		
		330	8×11.7	0.15	660	17	4000	RPS1A331MCN1GS	FP-010ME331M-PSR		
		330	10×7.7	0.12	660	20	3600	RPA1A331MCN1GS	FP-010ME331M-PAR		
16 (1C)	18.4	560	10×12.4	0.15	840	13	5300	RPS1A561MCN1GS	FP-010ME561M-PSR		
		33	6.3×5.7	0.10	211	40	1700	RPS1C330MCN1GS	FP-016ME330M-PSR		
		39	6.3×5.7	0.10	124	45	2000	RPS1C390MCN1GS	FP-016ME390M-PSR		
		39	6.3×5.7	0.10	124	24	2500	RPA1C390MCN1GS	FP-016ME390M-PAR		
		56	8×6.7	0.10	179	40	2300	RPS1C560MCN1GS	FP-016ME560M-PSR		
		82	8×6.7	0.10	262	40	2300	RPS1C820MCN1GS	FP-016ME820M-PSR		
		100	10×7.7	0.10	320	30	3200	RPS1C101MCN1GS	FP-016ME101M-PSR		
		150	10×7.7	0.10	480	30	3200	RPS1C151MCN1GS	FP-016ME151M-PSR		
		180	8×11.7	0.12	576	20	3700	RPS1C181MCN1GS	FP-016ME181M-PSR		
		180	10×7.7	0.12	576	20	3600	RPA1C181MCN1GS	FP-016ME181M-PAR		
		220	8×11.7	0.12	704	20	3700	RPS1C221MCN1GS	FP-016ME221M-PSR		
		220	10×7.7	0.10	704	22	3450	RPA1C221MCN1GS	FP-016ME221M-PAR		
		270	8×11.7	0.12	864	14	4400	RPS1C271MCN1GS	FP-016ME271M-PSR		
		330	10×12.4	0.12	792	16	4800	RPS1C331MCN1GS	FP-016ME331M-PSR		
		470	10×12.4	0.12	1504	9	6100	RPS1C471MCN1GS	FP-016ME471M-PSR		
20 (1D)	23.0	820	10×12.4	0.12	2624	18	4200	RPS1C821MCN1GS	FP-016ME821M-PSR		
		1000	10×12.4	0.12	3200	12	5400	RPS1C102MCN1GS	FP-016ME102M-PSR		
		1200	10×12.4	0.12	3840	12	5400	RPS1C122MCN1GS	FP-016ME122M-PSR		
		560	10×12.4	0.10	2240	20	3100	RPA1D561MCN1GS	FP-020ME561M-PAR		
		25 (1E)	28.7	22	8×6.7	0.12	275	50	1800	RPS1E220MCN1GS	FP-025ME220M-PSR
				100	8×11.7	0.12	500	24	3320	RPS1E101MCN1GS	FP-025ME101M-PSR
				220	8×11.7	0.12	1100	18	4400	RPS1E221MCN1GS	FP-025ME221M-PSR
				*330	10×12.4	0.08	1650	14	5000	RPS1E331MCNASQGS	FP-025ME331M-PSR-5K
				390	10×12.4	0.12	1950	16	4800	RPS1E391MCN1GS	FP-025ME391M-PSR
		35 (1V)	40.2	150	10×12.4	0.12	1050	28	2600	RPS1V151MCN1GS	FP-035ME151M-PSR
50 (1H)	57.5	12	6.3×5.7	0.12	120	40	1250	RPS1H120MCN1GS	FP-050ME120M-PSR		
		22	8×6.7	0.12	220	37	1550	RPS1H220MCN1GS	FP-050ME220M-PSR		
		33	10×7.7	0.12	330	32	1950	RPS1H330MCN1GS	FP-050ME330M-PSR		
		39	8×11.7	0.15	390	26	2300	RPS1H390MCN1GS	FP-050ME390M-PSR		
		47	8×11.7	0.15	470	26	2300	RPS1H470MCN1GS	FP-050ME470M-PSR		
		82	10×12.4	0.15	820	23	2800	RPS1H820MCN1GS	FP-050ME820M-PSR		
63 (1J)	72.5	8.2	6.3×5.7	0.12	103	41	1200	RPS1J8R2MCN1GS	FP-063ME8R2M-PSR		
		12	8×6.7	0.12	151	38	1500	RPS1J120MCN1GS	FP-063ME120M-PSR		
		22	10×7.7	0.12	277	33	1900	RPS1J220MCN1GS	FP-063ME220M-PSR		
		33	8×11.7	0.15	415	27	2250	RPS1J330MCN1GS	FP-063ME330M-PSR		
		56	10×12.4	0.15	705	24	2700	RPS1J560MCN1GS	FP-063ME560M-PSR		

* : Load life 5000hours.

• For taping specifications, recommended land size/soldering by reflow and minimum order quantity, please refer to the Guidelines for Aluminum Electrolytic Capacitors.

RHS / RHA High Capacitance (φ8)

- Low ESR, High Capacitance, High ripple current.
- Load life of 2000 / 5000 hours at 105°C.
- SMD type : Lead free reflow soldering condition at 260°C peak correspondence.
- Compliant to the RoHS directive (2011/65/EU,(EU)2015/863).



FPCAP

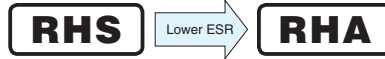

Specifications

Item	Performance Characteristics	
Category Temperature Range	-55 to +105°C	
Rated Voltage Range	2.5 to 35V	
Rated Capacitance Range	56 to 1500μF	
Capacitance Tolerance	±20% at 120Hz, 20°C	
Tangent of loss angle (tan δ)	Less than or equal to the specified value at 120Hz, 20°C	
ESR (※1)	Less than or equal to the specified value at 100kHz, 20°C	
Leakage Current (※2)	Less than or equal to the specified value. After 2 minutes' application of rated voltage at 20°C	
Endurance	Test condition	105°C, rated voltage 2000 / 5000Hrs.
	Capacitance change	Within ±20% of initial value before test
	tan δ	150% or less than the initial specified value
	ESR(※1)	150% or less than the initial specified value
	Leakage current (※2)	Less than or equal to the initial specified value

※1 ESR should be measured at both of the terminal ends closest where the terminals protrude through the plastic platform.

※2 Conditioning : If any doubt arises, measure the leakage current after the voltage treatment of applying DC rated voltage continuously to the capacitor for 120 minutes at 105°C.

Dimensions

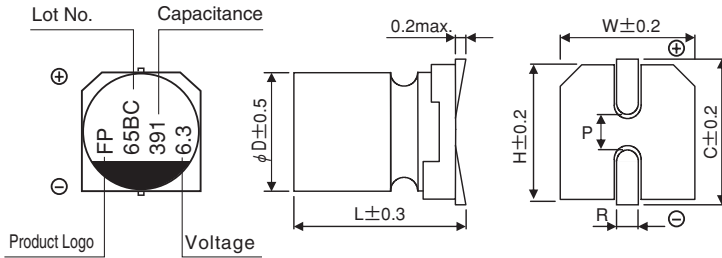

	(mm)					
φD×L	W	H	C	R	P	
8×6.7	8.3	8.3	9.0	0.8 to 1.1	3.2	
8×7.7	8.3	8.3	9.0	0.8 to 1.1	3.2	
8×8.7	8.3	8.3	9.0	0.8 to 1.1	3.2	
8×11.7	8.3	8.3	9.0	0.8 to 1.1	3.2	

Frequency coefficient of rated ripple current

Frequency	120 Hz	1 kHz	10 kHz	100 kHz	300 kHz
Coefficient	0.10	0.45	0.50	1.00	1.00

Type numbering system (Example : 6.3V 390μF) Nichicon part number

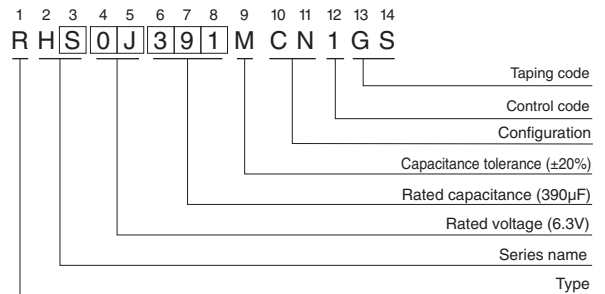

FPCAP part number

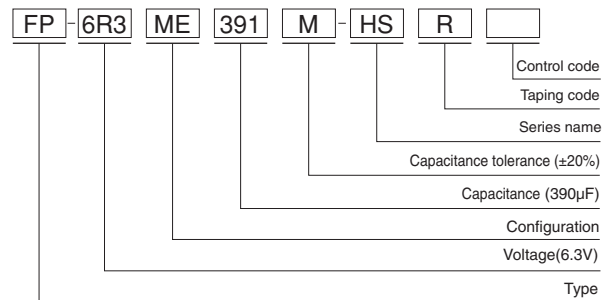

● Dimension table in next page.

RHS / RHA

■ Dimensions

Rated Voltage (V) (code)	Surge Voltage (V)	Rated Capacitance (μF)	Case Size φDxL (mm)	tan δ	Leakage Current (μA) (at 20°C after 2 minutes)	ESR (mΩ) (20°C/100kHz)	Rated Ripple Current (mA _{rms}) (105°C/100kHz)	NICHICON	FPCAP
2.5 (0E)	2.8	680	8x6.7	0.12	700	8	5000	RHA0E681MCN1GS	FP-2R5ME681M-HAR
		820	8x11.7	0.12	700	9	5400	RHS0E821MCN1GS	FP-2R5ME821M-HSR
		820	8x6.7	0.12	700	8	5000	RHA0E821MCN1GS	FP-2R5ME821M-HAR
		1000	8x7.7	0.12	750	8	5000	RHA0E102MCN1GS	FP-2R5ME102M-HAR
		1500	8x11.7	0.12	1125	9	5400	RHS0E152MCN1GS	FP-2R5ME152M-HSR
4.0 (0G)	4.6	560	8x6.7	0.12	700	16	3200	RHS0G561MCN1GS	FP-4R0ME561M-HSR
		560	8x6.7	0.12	700	8	5000	RHA0G561MCN1GS	FP-4R0ME561M-HAR
		680	8x7.7	0.12	816	8	5000	RHA0G681MCN1GS	FP-4R0ME681M-HAR
		1200	8x11.7	0.12	1440	9	5400	RHS0G122MCN1GS	FP-4R0ME122M-HSR
		1500	8x11.7	0.12	1800	12	4700	RHS0G152MCN1GS	FP-4R0ME152M-HSR
6.3 (0J)	7.2	330	8x6.7	0.12	700	9	4500	RHA0J331MCN1GS	FP-6R3ME331M-HAR
		390	8x6.7	0.12	737	18	3200	RHS0J391MCN1GS	FP-6R3ME391M-HSR
		390	8x6.7	0.12	737	9	4500	RHA0J391MCN1GS	FP-6R3ME391M-HAR
		470	8x6.7	0.12	888	9	4500	RHA0J471MCN1GS	FP-6R3ME471M-HAR
		560	8x7.7	0.12	1058	9	4500	RHA0J561MCN1GS	FP-6R3ME561M-HAR
		820	8x11.7	0.12	1549	10	5150	RHS0J821MCN1GS	FP-6R3ME821M-HSR
		1000	8x11.7	0.12	1890	10	5150	RHS0J102MCN1GS	FP-6R3ME102M-HSR
10 (1A)	11.5	150	8x6.7	0.12	700	25	3000	RHS1A151MCN1GS	FP-010ME151M-HSR
		330	8x7.7	0.12	660	19	3390	RHS1A331MCN1GS	FP-010ME331M-HSR
16 (1C)	18.4	150	8x6.7	0.12	700	22	3220	RHA1C151MCN1GS	FP-016ME151M-HAR
		270	8x6.7	0.12	864	22	3300	RHA1C271MCN1GS	FP-016ME271M-HAR
		270	8x8.7	0.12	864	16	4000	RHA1C271MCN9GS	FP-016ME271M-HAR-US
		*270	8x8.7	0.12	864	16	4070	RHA1C271MCNBSQGS	FP-016ME271M-HAR-5K-US
		330	8x8.7	0.12	1056	16	4000	RHA1C331MCN1GS	FP-016ME331M-HAR
		*330	8x8.7	0.12	1056	16	4070	RHA1C331MCNASQGS	FP-016ME331M-HAR-5K
		390	8x8.7	0.12	1248	16	4000	RHA1C391MCN1GS	FP-016ME391M-HAR
		*390	8x8.7	0.12	1248	16	4070	RHA1C391MCNASQGS	FP-016ME391M-HAR-5K
		470	8x8.7	0.12	1504	16	4000	RHA1C471MCN1GS	FP-016ME471M-HAR
		*470	8x8.7	0.12	1504	16	4070	RHA1C471MCNASQGS	FP-016ME471M-HAR-5K
		560	8x8.7	0.12	1792	16	4070	RHA1C561MCN1GS	FP-016ME561M-HAR
		560	8x11.7	0.12	1792	14	4950	RHS1C561MCN1GS	FP-016ME561M-HSR
		*560	8x8.7	0.12	1792	16	4070	RHA1C561MCNASQGS	FP-016ME561M-HAR-5K
		680	8x11.7	0.12	2176	14	4950	RHS1C681MCN1GS	FP-016ME681M-HSR
20 (1D)	23.0	390	8x11.7	0.12	1560	14	4950	RHS1D391MCN1GS	FP-020ME391M-HSR
25 (1E)	28.7	82	8x6.7	0.12	410	38	3200	RHA1E820MCN1GS	FP-025ME820M-HAR
		100	8x6.7	0.12	500	38	3200	RHA1E101MCN1GS	FP-025ME101M-HAR
		100	8x8.7	0.12	700	18	4000	RHS1E101MCN1GS	FP-025ME101M-HSR
		120	8x6.7	0.12	600	38	3200	RHA1E121MCN1GS	FP-025ME121M-HAR
		150	8x6.7	0.12	750	38	3200	RHA1E151MCN1GS	FP-025ME151M-HAR
35 (1V)	40.2	56	8x8.7	0.12	392	25	3000	RHS1V560MCN1GS	FP-035ME560M-HSR
		100	8x8.7	0.12	700	25	3000	RHS1V101MCN1GS	FP-035ME101M-HSR

* : Load life 5000hours.

■ Frequency Characteristics (The frequency characteristics are typical and not a guaranteed value.)

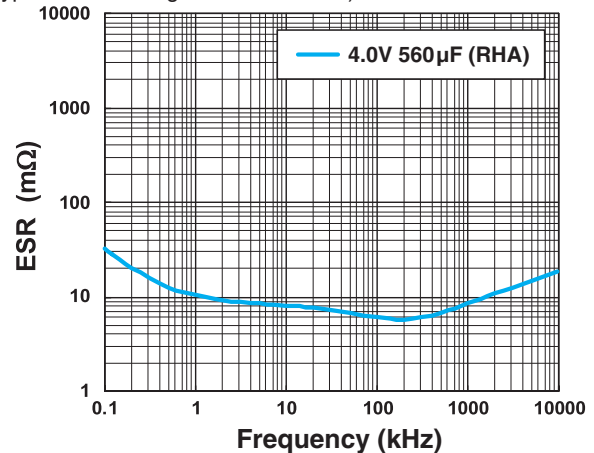
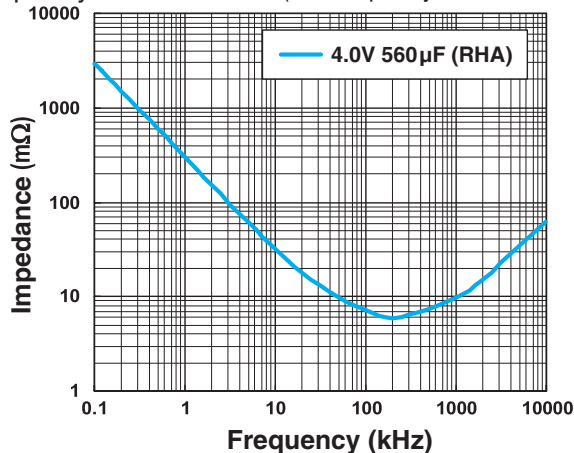

• For taping specifications, recommended land size/soldering by reflow and minimum order quantity, please refer to the Guidelines for Aluminum Electrolytic Capacitors.

RSS/RSA/RSB High Capacitance (φ6.3)

- Low ESR, High Capacitance, High ripple current.
- Load life of 2000 hours at 105°C.
- SMD type : Lead free reflow soldering condition at 260°C peak correspondence.
- Compliant to the RoHS directive (2011/65/EU,(EU)2015/863).

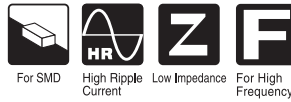

FPCAP



Specifications

Item	Performance Characteristics	
Category Temperature Range	-55 to +105°C	
Rated Voltage Range	2.5 to 35V	
Rated Capacitance Range	10 to 820μF	
Capacitance Tolerance	±20% at 120Hz, 20°C	
Tangent of loss angle (tan δ)	Less than or equal to the specified value at 120Hz, 20°C	
ESR (※1)	Less than or equal to the specified value at 100kHz, 20°C	
Leakage Current (※2)	Less than or equal to the specified value. After 2 minutes' application of rated voltage at 20°C	
Endurance	Test condition	105°C, rated voltage 2000Hrs.
	Capacitance change	Within ±20% of initial value before test
	tan δ	150% or less than the initial specified value
	ESR(※1)	150% or less than the initial specified value
	Leakage current (※2)	Less than or equal to the initial specified value

※1 ESR should be measured at both of the terminal ends closest where the terminals protrude through the plastic platform.

※2 Conditioning : If any doubt arises, measure the leakage current after the voltage treatment of applying DC rated voltage continuously to the capacitor for 120 minutes at 105°C.

Dimensions

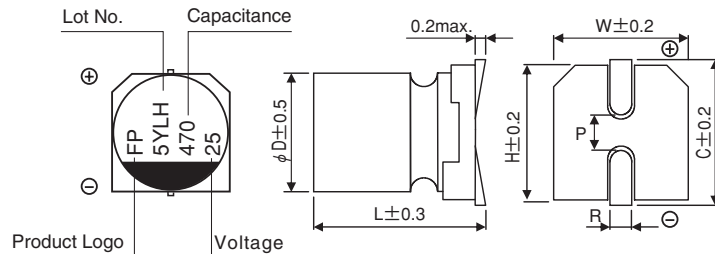

(mm)					
φD×L	W	H	C	R	P
6.3×5.7	6.5	6.5	7.2	0.5 to 0.9	2.1
6.3×7.7	6.5	6.5	7.2	0.5 to 0.9	2.1

Type numbering system (Example : 25V 47μF)

Nichicon part number

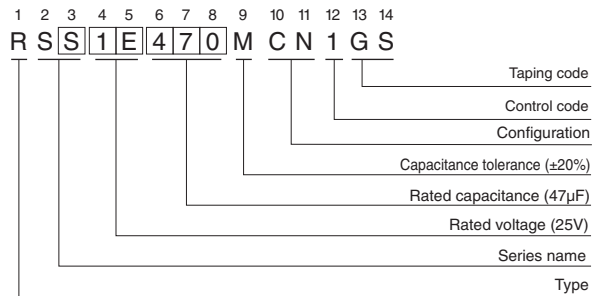

Frequency coefficient of rated ripple current

Frequency	120 Hz	1 kHz	10 kHz	100 kHz	300 kHz
Coefficient	0.10	0.45	0.50	1.00	1.00

FPCAP part number

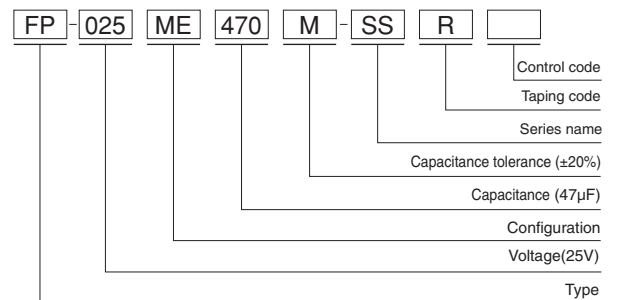

RSS / RSA / RSB

■ Dimensions

Rated Voltage (V) (code)	Surge Voltage (V)	Rated Capacitance (μF)	Case Size φD×L (mm)	tan δ	Leakage Current (μA) (at 20°C after 2 minutes)	ESR (mΩ) (20°C/100kHz)	Rated Ripple Current (mA) (105°C/100kHz)	NICHICON	FPCAP
2.5 (0E)	2.8	330	6.3×5.7	0.12	700	14	3160	RSA0E331MCN1GS	FP-2R5ME331M-SAR
		390	6.3×5.7	0.12	700	14	3160	RSA0E391MCN1GS	FP-2R5ME391M-SAR
		390	6.3×5.7	0.12	700	10	3650	RSB0E391MCN1GS	FP-2R5ME391M-SBR
		470	6.3×5.7	0.12	700	13	3600	RSA0E471MCN1GS	FP-2R5ME471M-SAR
		560	6.3×5.7	0.12	700	25	2500	RSS0E561MCN1GS	FP-2R5ME561M-SSR
		560	6.3×5.7	0.12	700	13	3600	RSA0E561MCN1GS	FP-2R5ME561M-SAR
		560	6.3×5.7	0.12	700	10	3800	RSB0E561MCN1GS	FP-2R5ME561M-SBR
4.0 (0G)	4.6	330	6.3×5.7	0.12	700	14	3160	RSA0G331MCN1GS	FP-4R0ME331M-SAR
		330	6.3×5.7	0.12	700	11	3700	RSB0G331MCN1GS	FP-4R0ME331M-SBR
		390	6.3×5.7	0.12	700	14	3160	RSA0G391MCN1GS	FP-4R0ME391M-SAR
6.3 (0J)	7.2	100	6.3×5.7	0.12	700	25	2500	RSS0J101MCN1GS	FP-6R3ME101M-SSR
		220	6.3×5.7	0.12	700	25	2500	RSS0J221MCN1GS	FP-6R3ME221M-SSR
		220	6.3×5.7	0.12	700	15	3160	RSA0J221MCN1GS	FP-6R3ME221M-SAR
		220	6.3×5.7	0.12	700	12	3500	RSB0J221MCN1GS	FP-6R3ME221M-SBR
		270	6.3×5.7	0.12	700	14	3160	RSA0J271MCN1GS	FP-6R3ME271M-SAR
		330	6.3×5.7	0.12	700	25	2500	RSS0J331MCN1GS	FP-6R3ME331M-SSR
		330	6.3×5.7	0.12	700	14	3160	RSA0J331MCN1GS	FP-6R3ME331M-SAR
10 (1A)	11.5	120	6.3×5.7	0.12	700	18	2900	RSA1A121MCN1GS	FP-010ME121M-SAR
		220	6.3×5.7	0.12	500	20	3000	RSA1A221MCN1GS	FP-010ME221M-SAR
16 (1C)	18.4	100	6.3×5.7	0.12	700	24	2490	RSS1C101MCN1GS	FP-016ME101M-SSR
		100	6.3×7.7	0.12	700	24	2700	RSA1C101MCN1GS	FP-016ME101M-SAR
		180	6.3×5.7	0.12	576	22	3300	RSA1C181MCN1GS	FP-016ME181M-SAR
		220	6.3×7.7	0.12	704	20	3500	RSA1C221MCN1GS	FP-016ME221M-SAR
		270	6.3×7.7	0.12	864	15	3800	RSA1C271MCN1GS	FP-016ME271M-SAR
20 (1D)	23.0	39	6.3×5.7	0.12	156	25	2800	RSS1D390MCN1GS	FP-020ME390M-SSR
		47	6.3×5.7	0.12	188	25	2800	RSS1D470MCN1GS	FP-020ME470M-SSR
		56	6.3×5.7	0.12	224	25	2800	RSS1D560MCN1GS	FP-020ME560M-SSR
		68	6.3×5.7	0.12	272	25	2800	RSS1D680MCN1GS	FP-020ME680M-SSR
		82	6.3×5.7	0.12	328	25	2800	RSS1D820MCN1GS	FP-020ME820M-SSR
		150	6.3×7.7	0.12	600	25	3200	RSA1D151MCN1GS	FP-020ME151M-SAR
25 (1E)	28.7	10	6.3×5.7	0.12	100	60	1700	RSS1E100MCN1GS	FP-025ME100M-SSR
		22	6.3×5.7	0.12	110	40	2100	RSS1E220MCN1GS	FP-025ME220M-SSR
		27	6.3×5.7	0.12	135	40	2600	RSS1E270MCN1GS	FP-025ME270M-SSR
		47	6.3×5.7	0.12	235	30	2800	RSS1E470MCN1GS	FP-025ME470M-SSR
		56	6.3×5.7	0.12	280	30	2800	RSS1E560MCN1GS	FP-025ME560M-SSR
		68	6.3×5.7	0.12	340	30	2800	RSS1E680MCN1GS	FP-025ME680M-SSR
		100	6.3×7.7	0.12	500	22	3100	RSA1E101MCN1GS	FP-025ME101M-SAR
35 (1V)	40.2	10	6.3×5.7	0.12	100	60	1700	RSS1V100MCN1GS	FP-035ME100M-SSR

■ Frequency Characteristics (The frequency characteristics are typical and not a guaranteed value.)

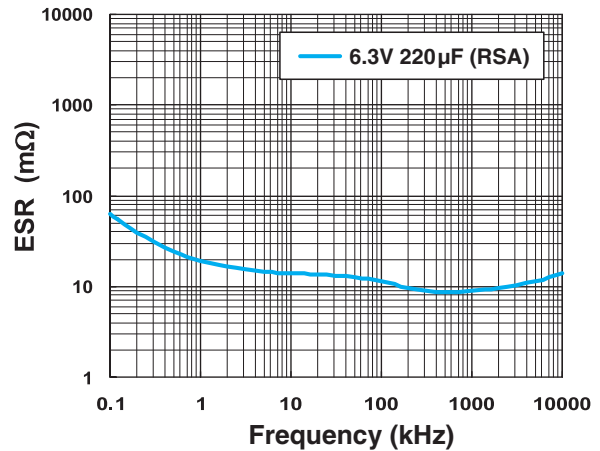
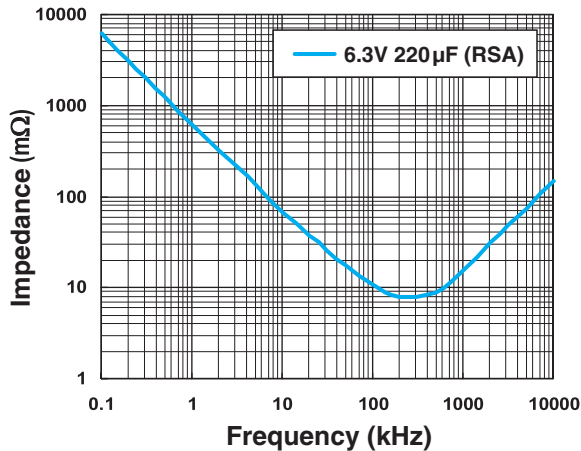

• For taping specifications, recommended land size/soldering by reflow and minimum order quantity, please refer to the Guidelines for Aluminum Electrolytic Capacitors.

RFS/RFA High Capacitance (φ4, φ5)

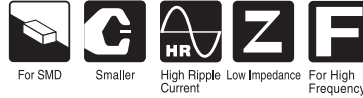

FPCAP



- Low ESR, High Capacitance, High ripple current.
- Load life of 2000 hours at 105°C.
- SMD type : Lead free reflow soldering condition at 260°C peak correspondence.
- Compliant to the RoHS directive (2011/65/EU,(EU)2015/863).

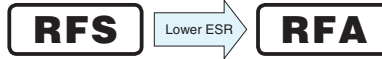

Specifications

Item	Performance Characteristics	
Category Temperature Range	-55 to +105°C	
Rated Voltage Range	2.5 to 25V	
Rated Capacitance Range	10 to 330μF	
Capacitance Tolerance	±20% at 120Hz, 20°C	
Tangent of loss angle (tan δ)	Less than or equal to the specified value at 120Hz, 20°C	
ESR (※1)	Less than or equal to the specified value at 100kHz, 20°C	
Leakage Current (※2)	Less than or equal to the specified value. After 2 minutes' application of rated voltage at 20°C	
Endurance	Test condition	105°C, rated voltage 2000Hrs.
	Capacitance change	Within ±20% of initial value before test
	tan δ	150% or less than the initial specified value
	ESR(※1)	150% or less than the initial specified value
	Leakage current (※2)	Less than or equal to the initial specified value

※1 ESR should be measured at both of the terminal ends closest where the terminals protrude through the plastic platform.

※2 Conditioning : If any doubt arises, measure the leakage current after the voltage treatment of applying DC rated voltage continuously to the capacitor for 120 minutes at 105°C.

Dimensions

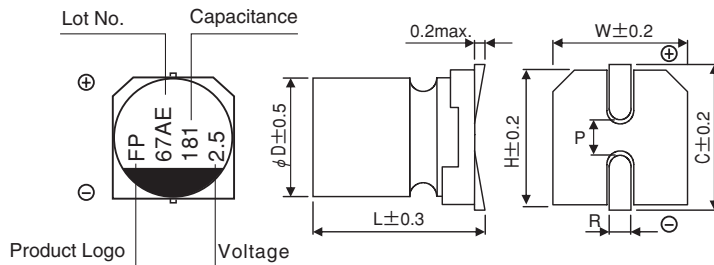

Type numbering system (Example : 2.5V 180μF)
Nichicon part number

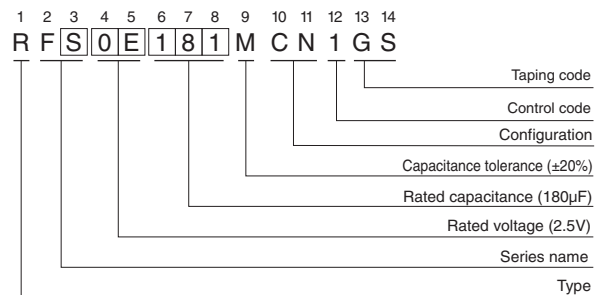

(mm)

φD×L	W	H	C	R	P
4×5.2	4.3	4.3	5.1	0.5 to 0.9	1.0
5×5.7	5.3	5.3	5.9	0.5 to 0.9	1.4

FPCAP part number

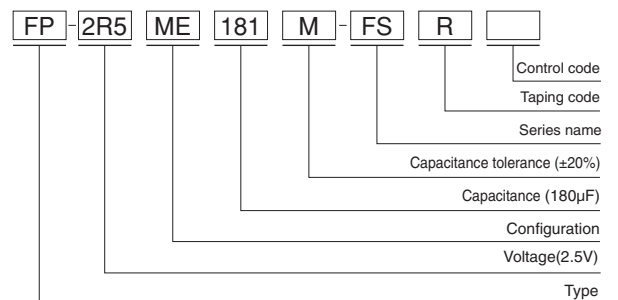

Frequency coefficient of rated ripple current

Frequency	120 Hz	1 kHz	10 kHz	100 kHz	300 kHz
Coefficient	0.10	0.45	0.50	1.00	1.00

RFS / RFA

■ Dimensions

Rated Voltage (V) (code)	Surge Voltage (V)	Rated Capacitance (μF)	Case Size φD×L (mm)	tan δ	Leakage Current (μA) (at 20°C after 2 minutes)	ESR (mΩ) (20°C/100kHz)	Rated Ripple Current (mA _{rms}) (105°C/100kHz)	NICHICON	FPCAP
2.5 (0E)	2.8	180	5×5.7	0.12	300	21	2670	RFS0E181MCN1GS	FP-2R5ME181M-FSR
		330	5×5.7	0.12	500	10	3300	RFA0E331MCN1GS	FP-2R5ME331M-FAR
4.0 (0G)	4.6	100	5×5.7	0.12	300	22	2610	RFS0G101MCN1GS	FP-4R0ME101M-FSR
		150	5×5.7	0.12	300	22	2610	RFS0G151MCN1GS	FP-4R0ME151M-FSR
6.3 (0J)	7.2	47	5×5.7	0.12	300	30	2000	RFS0J470MCN1GS	FP-6R3ME470M-FSR
		100	5×5.7	0.12	300	24	2500	RFS0J101MCN1GS	FP-6R3ME101M-FSR
		120	5×5.7	0.12	300	24	2500	RFS0J121MCN1GS	FP-6R3ME121M-FSR
		180	5×5.7	0.12	567	17	3390	RFA0J181MCN1GS	FP-6R3ME181M-FAR
10 (1A)	11.5	10	4×5.2	0.12	100	220	700	RFS1A100MCN1GB	FP-010ME100M-FSR
		68	5×5.7	0.12	300	30	2000	RFS1A680MCN1GS	FP-010ME680M-FSR
16 (1C)	18.4	22	5×5.7	0.12	100	45	1210	RFS1C220MCN1GS	FP-016ME220M-FSR
		33	5×5.7	0.12	105	35	2070	RFS1C330MCN1GS	FP-016ME330M-FSR
		39	5×5.7	0.12	124	35	2070	RFS1C390MCN1GS	FP-016ME390M-FSR
		100	5×5.7	0.12	320	27	3000	RFS1C101MCN1GS	FP-016ME101M-FSR
25 (1E)	28.7	22	5×5.7	0.12	300	40	2200	RFS1E220MCN1GS	FP-025ME220M-FSR
		27	5×5.7	0.12	135	40	2450	RFS1E270MCN1GS	FP-025ME270M-FSR

■ Frequency Characteristics (The frequency characteristics are typical and not a guaranteed value.)

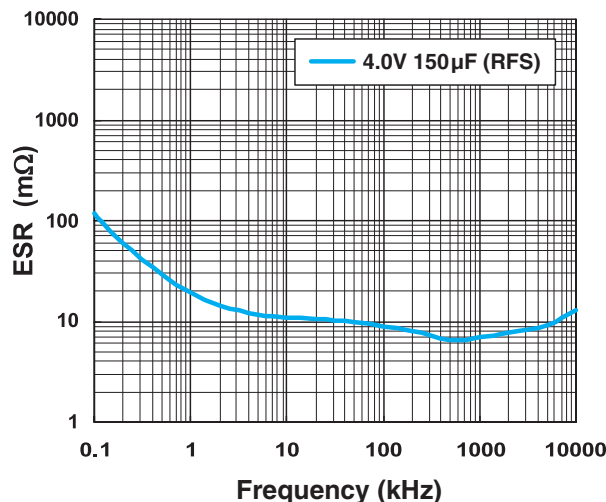
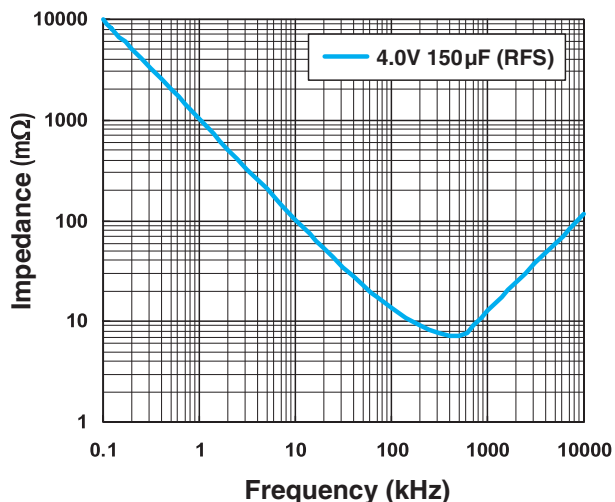

• For taping specifications, recommended land size/soldering by reflow and minimum order quantity, please refer to the Guidelines for Aluminum Electrolytic Capacitors.

RSL

Low Profile ($\phi 6.3$)

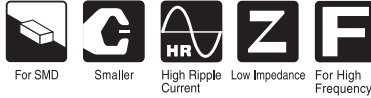

FPCAP



- Low ESR, High Capacitance, High ripple current.
- Low Profile (Height 4.2mm).
- Load life of 2000 hours at 105°C.
- SMD type : Lead free reflow soldering condition at 260°C peak correspondence.
- Compliant to the RoHS directive (2011/65/EU,(EU)2015/863).



■ Specifications

Item	Performance Characteristics	
Category Temperature Range	-55 to +105°C	
Rated Voltage Range	2.5 to 25V	
Rated Capacitance Range	15 to 330 μ F	
Capacitance Tolerance	$\pm 20\%$ at 120Hz, 20°C	
Tangent of loss angle (tan δ)	Less than or equal to the specified value at 120Hz, 20°C	
ESR (※1)	Less than or equal to the specified value at 100kHz, 20°C	
Leakage Current (※2)	Less than or equal to the specified value. After 2 minutes' application of rated voltage at 20°C	
Endurance	Test condition	105°C, rated voltage 2000Hrs.
	Capacitance change	Within $\pm 20\%$ of initial value before test
	tan δ	150% or less than the initial specified value
	ESR(※1)	150% or less than the initial specified value
	Leakage current (※2)	Less than or equal to the initial specified value

※1 ESR should be measured at both of the terminal ends closest where the terminals protrude through the plastic platform.
 ※2 Conditioning : If any doubt arises, measure the leakage current after the voltage treatment of applying DC rated voltage continuously to the capacitor for 120 minutes at 105°C.

■ Dimensions

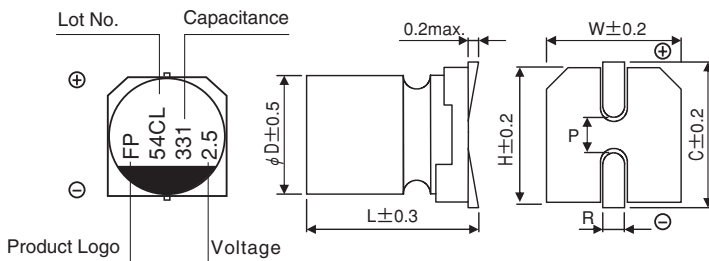

(mm)					
$\phi D \times L$	W	H	C	R	P
6.3 \times 4.2	6.5	6.5	7.2	0.5 to 0.9	2.1

Type numbering system (Example : 2.5V 330 μ F)
 Nichicon part number

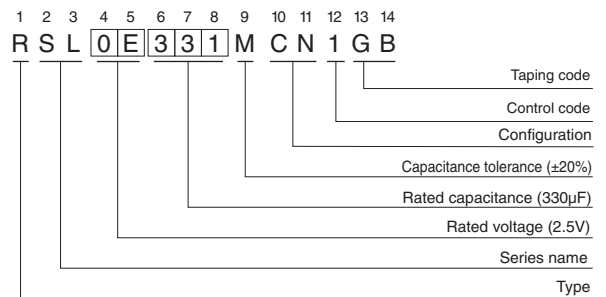

● Frequency coefficient of rated ripple current

Frequency	120 Hz	1 kHz	10 kHz	100 kHz	300 kHz
Coefficient	0.10	0.45	0.50	1.00	1.00

FPCAP part number

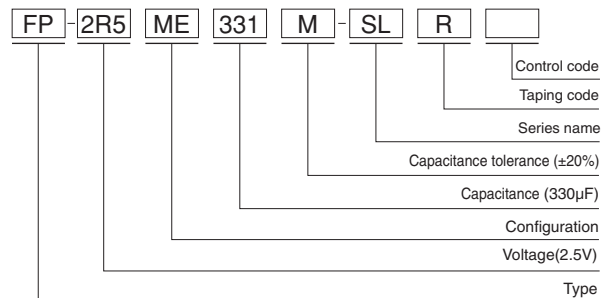

RSL

■ Dimensions

Rated Voltage (V) (code)	Surge Voltage (V)	Rated Capacitance (μF)	Case Size φD×L (mm)	tan δ	Leakage Current (μA) (at 20°C after 2 minutes)	ESR (mΩ) (20°C/100kHz)	Rated Ripple Current (mA) (105°C/100kHz)	NICHICON	FPCAP
2.5 (0E)	2.8	100	6.3×4.2	0.12	300	16	3500	RSL0E101MCN1GB	FP-2R5ME101M-SLR
		220	6.3×4.2	0.12	300	16	3500	RSL0E221MCN1GB	FP-2R5ME221M-SLR
		330	6.3×4.2	0.12	412	16	3500	RSL0E331MCN1GB	FP-2R5ME331M-SLR
6.3 (0J)	7.2	100	6.3×4.2	0.12	315	18	3200	RSL0J101MCN1GB	FP-6R3ME101M-SLR
		150	6.3×4.2	0.12	472	18	3200	RSL0J151MCN1GB	FP-6R3ME151M-SLR
		220	6.3×4.2	0.12	693	18	3200	RSL0J221MCN1GB	FP-6R3ME221M-SLR
10 (1A)	11.5	100	6.3×4.2	0.12	500	25	2500	RSL1A101MCN1GB	FP-010ME101M-SLR
16 (1C)	18.4	15	6.3×4.2	0.12	300	45	1900	RSL1C150MCN1GB	FP-016ME150M-SLR
25 (1E)	28.7	15	6.3×4.2	0.12	100	55	1700	RSL1E150MCN1GB	FP-025ME150M-SLR

■ Frequency Characteristics (The frequency characteristics are typical and not a guaranteed value.)

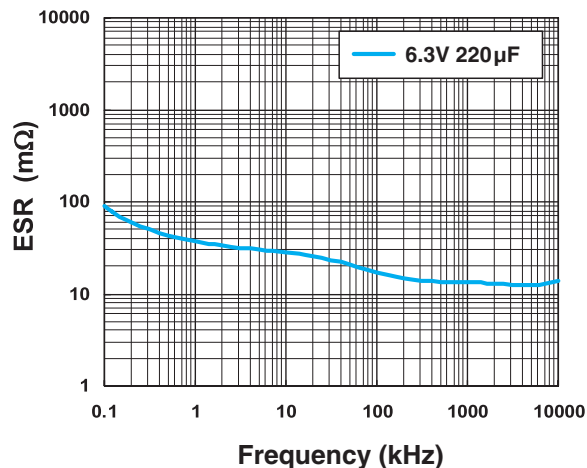
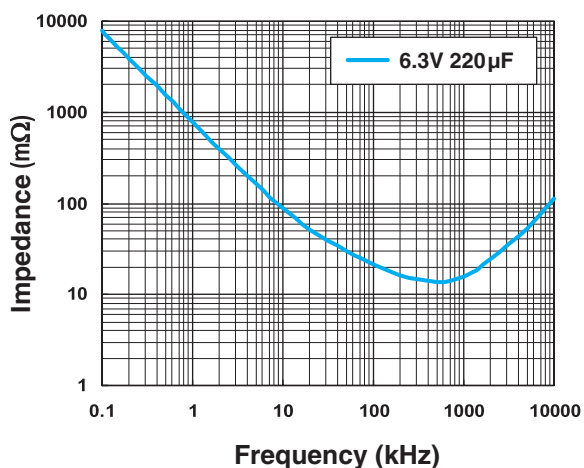

• For taping specifications, recommended land size/soldering by reflow and minimum order quantity, please refer to the Guidelines for Aluminum Electrolytic Capacitors.

RDS High Capacitance,
Load life of 3000 hours at 125°C



FPCAP **NEW**

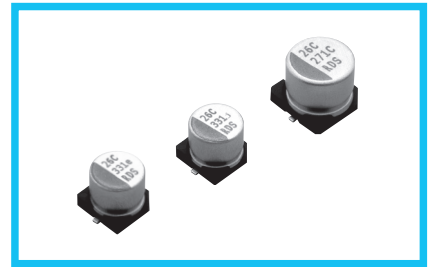

- High Capacitance, High ripple current.
- Load life of 3000 hours at 125°C.
- SMD type : Lead free reflow soldering condition at 260°C peak correspondence.
- Compliant to the RoHS directive (2011/65/EU,(EU)2015/863).

■ Specifications

Item	Performance Characteristics	
Category Temperature Range	-55 to +125°C	
Rated Voltage Range	2.5 to 16V	
Rated Capacitance Range	33 to 820μF	
Capacitance Tolerance	±20% at 120Hz, 20°C	
Tangent of loss angle (tan δ)	Less than or equal to the specified value at 120Hz, 20°C	
ESR (※ 1)	Less than or equal to the specified value at 100kHz, 20°C	
Leakage Current (※ 2)	After 2 minutes' application of rated voltage, leakage current is not more than 0.3CV or 700(μA), whichever is greater. ※	
Endurance	Test condition	125°C, rated voltage, 3000Hrs
	Capacitance change	Within ±20% of initial value before test
	tan δ	150% or less than the initial specified value
	ESR (※ 1)	150% or less than the initial specified value
	Leakage current (※ 2)	Less than or equal to the specified value

※ 1 ESR should be measured at both of the terminal ends closest where the terminals protrude through the plastic platform. ※ I : Leakage Current (μA), C : Rated Capacitance (μF), V : Rated Voltage (V)
 ※ 2 Conditioning : If any doubt arises, measure the leakage current after the voltage treatment of applying DC rated voltage continuously to the capacitor for 120 minutes at 105°C.

■ Dimensions

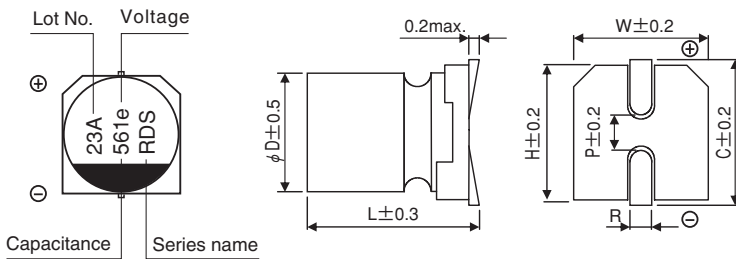

(mm)

Size Code	φD×L	W	H	C	R	P
FE	6.3×5.7	6.5	6.5	7.2	0.5 to 0.9	2.1
HF	8×6.7	8.3	8.3	9.0	0.8 to 1.1	3.2

Type numbering system (Example : 2.5V 560μF)

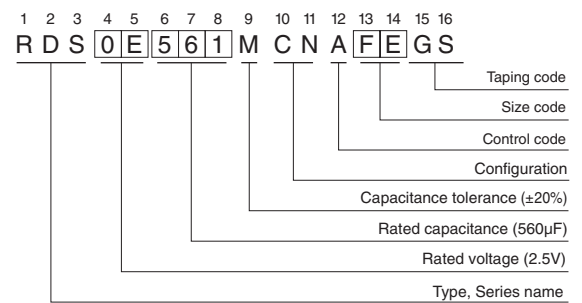

● Frequency coefficient of rated ripple current

Frequency	120 Hz	1 kHz	10 kHz	100 kHz	300 kHz
Coefficient	0.10	0.45	0.50	1.00	1.00

RDS

■ Dimensions

Rated Voltage (V) (code)	Surge Voltage (V)	Rated Capacitance (μF)	Case Size φD×L (mm)	tan δ	Leakage Current (μA) (at 20°C after 2 minutes)	ESR (mΩ) (20°C/100kHz)	Rated Ripple Current (mA _{rms} /100kHz)		Part Number
							≤105°C (*3)	105°C< ≤125°C (*3)	
2.5 (0E)	2.8	330	6.3×5.7	0.12	700	25	2450	1050	RDS0E331MCNAFEFS
		390	6.3×5.7	0.12	700	25	2650	1250	RDS0E391MCNAFEFS
		470	6.3×5.7	0.12	700	25	2450	1050	RDS0E471MCNAFEFS
			8×6.7	0.12	700	18	4700	2250	RDS0E471MCNAHFGS
		500	6.3×5.7	0.12	700	25	2450	1050	RDS0E501MCNAFEFS
			8×6.7	0.12	700	18	4500	2050	RDS0E501MCNAHFGS
		560	6.3×5.7	0.12	700	25	2450	1050	RDS0E561MCNAFEFS
			8×6.7	0.12	700	18	4500	2050	RDS0E561MCNAHFGS
680	8×6.7	0.12	700	18	4500	2050	RDS0E681MCNAHFGS		
820	8×6.7	0.12	700	18	4500	2050	RDS0E821MCNAHFGS		
4.0 (0G)	4.6	220	8×6.7	0.12	700	18	2450	1050	RDS0G221MCNAHFGS
		270	8×6.7	0.12	700	18	2450	1050	RDS0G271MCNAHFGS
		330	6.3×5.7	0.12	700	25	2450	1050	RDS0G331MCNAFEFS
			8×6.7	0.12	700	18	2450	1050	RDS0G331MCNAHFGS
		390	6.3×5.7	0.12	700	25	2450	1050	RDS0G391MCNAFEFS
			8×6.7	0.12	700	18	2450	1050	RDS0G391MCNAHFGS
		470	8×6.7	0.12	700	18	2450	1050	RDS0G471MCNAHFGS
		500	8×6.7	0.12	700	18	2450	1050	RDS0G501MCNAHFGS
560	8×6.7	0.12	700	18	2450	1050	RDS0G561MCNAHFGS		
6.3 (0J)	7.2	82	6.3×5.7	0.12	700	25	2500	1050	RDS0J820MCNAFEFS
		100	6.3×5.7	0.12	700	25	2500	1050	RDS0J101MCNAFEFS
		120	6.3×5.7	0.12	700	25	2500	1050	RDS0J121MCNAFEFS
		150	6.3×5.7	0.12	700	25	2500	1050	RDS0J151MCNAFEFS
			8×6.7	0.12	700	18	4650	2350	RDS0J151MCNAHFGS
		180	6.3×5.7	0.12	700	25	2500	1050	RDS0J181MCNAFEFS
			8×6.7	0.12	700	18	4300	2050	RDS0J181MCNAHFGS
		220	6.3×5.7	0.12	700	25	2950	1450	RDS0J221MCNAFEFS
			8×6.7	0.12	700	18	4300	2050	RDS0J221MCNAHFGS
		270	6.3×5.7	0.12	700	25	2550	1050	RDS0J271MCNAFEFS
			8×6.7	0.12	700	18	4300	2050	RDS0J271MCNAHFGS
		330	6.3×5.7	0.12	700	25	3250	1800	RDS0J331MCNAFEFS
8×6.7	0.12		700	18	4900	2400	RDS0J331MCNAHFGS		
390	8×6.7	0.12	737	18	4300	2050	RDS0J391MCNAHFGS		
470	8×6.7	0.12	888	18	4300	2150	RDS0J471MCNAHFGS		
10 (1A)	11.5	47	6.3×5.7	0.12	700	25	3700	1800	RDS1A470MCNAFEFS
		56	6.3×5.7	0.12	700	25	3700	1800	RDS1A560MCNAFEFS
		68	6.3×5.7	0.12	700	25	3700	1800	RDS1A680MCNAFEFS
		82	6.3×5.7	0.12	700	25	3700	1800	RDS1A820MCNAFEFS
		100	6.3×5.7	0.12	700	25	3700	1800	RDS1A101MCNAFEFS
		120	6.3×5.7	0.12	700	25	3700	1800	RDS1A121MCNAFEFS
			8×6.7	0.12	700	18	4650	2450	RDS1A121MCNAHFGS
		150	6.3×5.7	0.12	700	25	3700	1800	RDS1A151MCNAFEFS
			8×6.7	0.12	700	18	4550	2250	RDS1A151MCNAHFGS
		180	6.3×5.7	0.12	700	25	3700	1800	RDS1A181MCNAFEFS
220	6.3×5.7	0.12	700	25	3700	1800	RDS1A221MCNAFEFS		

(*3) Ambient temperature of a capacitor

RDS

■ Dimensions

Rated Voltage (V) (code)	Surge Voltage (V)	Rated Capacitance (μF)	Case Size φD×L (mm)	tan δ	Leakage Current (μA) (at 20°C after 2 minutes)	ESR (mΩ) (20°C/100kHz)	Rated Ripple Current (mA _{rms} /100kHz)		Part Number
							≤105°C (*3)	105°C < ≤125°C (*3)	
16 (1C)	18.4	33	6.3×5.7	0.12	700	24	3850	2100	RDS1C330MCNAFEFS
		39	6.3×5.7	0.12	700	24	3750	1800	RDS1C390MCNAFEFS
		47	6.3×5.7	0.12	700	24	3750	1800	RDS1C470MCNAFEFS
		56	6.3×5.7	0.12	700	24	3750	1800	RDS1C560MCNAFEFS
			8×6.7	0.12	700	23	4500	2450	RDS1C560MCNAHFGS
		68	6.3×5.7	0.12	700	24	3750	1800	RDS1C680MCNAFEFS
			8×6.7	0.12	700	23	3600	1800	RDS1C680MCNAHFGS
		82	6.3×5.7	0.12	700	24	3750	1800	RDS1C820MCNAFEFS
			8×6.7	0.12	700	23	3600	1800	RDS1C820MCNAHFGS
		100	6.3×5.7	0.12	700	24	3700	1850	RDS1C101MCNAFEFS
			8×6.7	0.12	700	23	3600	1800	RDS1C101MCNAHFGS
		120	6.3×5.7	0.12	700	24	3750	1800	RDS1C121MCNAFEFS
			8×6.7	0.12	700	23	3600	1800	RDS1C121MCNAHFGS
		150	6.3×5.7	0.12	720	24	3750	1800	RDS1C151MCNAFEFS
8×6.7	0.12		720	23	3600	1800	RDS1C151MCNAHFGS		
180	8×6.7	0.12	864	23	3600	1800	RDS1C181MCNAHFGS		
220	8×6.7	0.12	1056	23	3600	1800	RDS1C221MCNAHFGS		
270	8×6.7	0.12	1296	23	3600	1800	RDS1C271MCNAHFGS		

(*3) Ambient temperature of a capacitor

■ Frequency Characteristics (The frequency characteristics are typical and not a guaranteed value.)

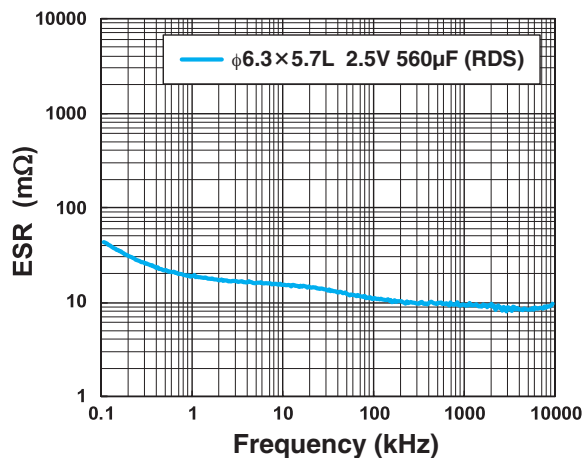
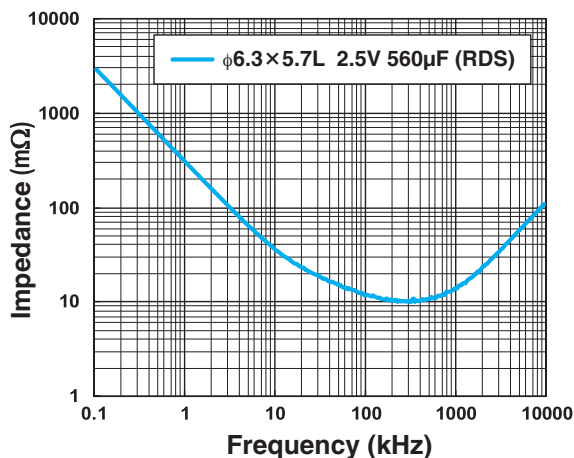

• For taping specifications, recommended land size/soldering by reflow and minimum order quantity, please refer to the Guidelines for Aluminum Electrolytic Capacitors.

RKS High Capacitance,
Load life of 3000 hours at 125°C

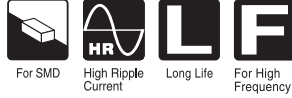

FPCAP **NEW**

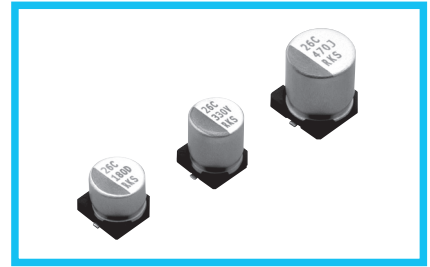

- Low LC, high allowable ripple current product.
- 85°C 85% 1000H, Load life of 3000 hours at 125°C.
- SMD type : Lead free reflow soldering condition at 260°C peak correspondence.
- Compliant to the RoHS directive (2011/65/EU,(EU)2015/863).

■ Specifications

Item	Performance Characteristics	
Category Temperature Range	-55 to +125°C	
Rated Voltage Range	20 to 63V	
Rated Capacitance Range	8.2 to 390μF	
Capacitance Tolerance	±20% at 120Hz, 20°C	
Tangent of loss angle (tan δ)	Less than or equal to the specified value at 120Hz, 20°C	
ESR (* 1)	Less than or equal to the specified value at 100kHz, 20°C	
Leakage Current (* 2)	After 2 minutes' application of rated voltage, leakage current is not more than 0.05CV or 100(μA), whichever is greater. ※	
Endurance	Test condition	125°C, rated voltage, 3000Hrs
	Capacitance change	Within ±20% of initial value before test
	tan δ	150% or less than the initial specified value
	ESR (* 1)	150% or less than the initial specified value
	Leakage current (* 2)	Less than or equal to the specified value
Shelf Life	After storing the capacitors under no load at 125°C for 1000 hours and then performing voltage treatment based on JIS C 5101-4 clause 4.1 at 20°C, they shall meet the specified values for the endurance characteristics listed above.	
Damp Heat (Steady State)	The specifications listed at right shall be met when the capacitors are restored to 20°C after the rated voltage is applied for 1000 hours at 85°C, 85% R.H.	
	Capacitance change	Within ± 20% of initial capacitance value (* 3)
	tan δ	150% or less of the initial specified value
	ESR (* 1)	150% or less of the initial specified value
Resistance to Soldering Heat	After soldering the capacitor under the soldering conditions prescribed here, the capacitor shall meet the specifications listed at right. Pre-heating shall be done at 150 to 180°C : within 90 seconds, Over 200°C : within 60 seconds, 260°C : within 5 seconds. in case peak temperature is 260°C or less, reflow soldering shall be two times maximum. Measurement for solder temperature profile shall be made at the capacitor top.	
	Capacitance change	Within ±10% of initial capacitance value (* 3)
	tan δ	150% or less than the initial specified value
	ESR (* 1)	150% or less than the initial specified value
	Leakage current (* 2)	Less than or equal to the initial specified value
Marking	Navy blue print on the case top	

- ※ 1 ESR should be measured at both of the terminal ends closest where the terminals protrude through the plastic platform.
- ※ 2 Conditioning : If any doubt arises, measure the leakage current after the voltage treatment of applying DC rated voltage continuously to the capacitor for 120 minutes at 105°C.
- ※ 3 Initial value : The value before test of examination of resistance to soldering.

※ I : Leakage Current (μA), C : Rated Capacitance (μF), V : Rated Voltage (V)

■ Dimensions

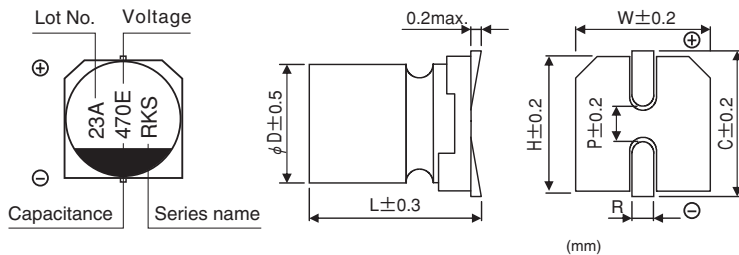

Size Code	φD×L	W	H	C	R	P
FE	6.3×5.8	6.5	6.5	7.2	0.5 to 0.9	2.1
FG	6.3×7.7	6.5	6.5	7.2	0.5 to 0.9	2.1
HF	8×6.7	8.3	8.3	9.0	0.8 to 1.1	3.2
HG	8×7.7	8.3	8.3	9.0	0.8 to 1.1	3.2
HH	8×8.7	8.3	8.3	9.0	0.8 to 1.1	3.2

Type numbering system (Example : 25V 47μF)

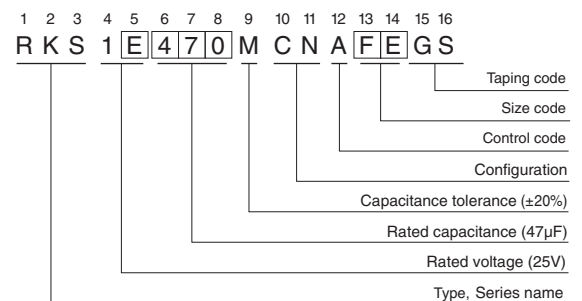

● Frequency coefficient of rated ripple current

Frequency	120 Hz	1 kHz	10 kHz	100 kHz	300 kHz
Coefficient	0.10	0.45	0.50	1.00	1.00

● Dimension table in next page.

RKS

■ Dimensions

Rated Voltage (V) (code)	Surge Voltage (V)	Rated Capacitance (μF)	Case Size φD×L (mm)	tan δ	Leakage Current (μA) (at 20°C after 2 minutes)	ESR (mΩ) (20°C/100kHz)	Rated Ripple Current (mArms/100kHz)		Part Number
							≤105°C (*4)	105°C < ≤125°C (*4)	
20 (1D)	23	18	6.3×5.8	0.12	100	50	1900	900	RKS1D180MCNAFEFS
		22	6.3×5.8	0.12	100	50	1900	900	RKS1D220MCNAFEFS
		27	6.3×5.8	0.12	100	50	1900	900	RKS1D270MCNAFEFS
			6.3×7.7	0.12	100	30	2900	1400	RKS1D270MCNAFGGS
		33	6.3×5.8	0.12	100	50	1900	900	RKS1D330MCNAFEFS
			6.3×7.7	0.12	100	30	2900	1400	RKS1D330MCNAFGGS
			8×6.7	0.12	100	30	3160	1600	RKS1D330MCNAHFGS
		39	6.3×5.8	0.12	100	50	1900	900	RKS1D390MCNAFEFS
			6.3×7.7	0.12	100	30	2900	1400	RKS1D390MCNAFGGS
			8×6.7	0.12	100	30	3160	1600	RKS1D390MCNAHFGS
			8×7.7	0.12	100	30	3160	1600	RKS1D390MCNAHGGGS
		47	6.3×5.8	0.12	100	50	1900	900	RKS1D470MCNAFEFS
			6.3×7.7	0.12	100	30	2900	1400	RKS1D470MCNAFGGS
			8×6.7	0.12	100	30	3160	1600	RKS1D470MCNAHFGS
			8×7.7	0.12	100	30	3160	1600	RKS1D470MCNAHGGGS
		56	6.3×5.8	0.12	100	50	1900	900	RKS1D560MCNAFEFS
			6.3×7.7	0.12	100	30	2900	1400	RKS1D560MCNAFGGS
			8×6.7	0.12	100	30	3160	1600	RKS1D560MCNAHFGS
			8×7.7	0.12	100	30	3160	1600	RKS1D560MCNAHGGGS
			8×8.7	0.12	100	30	3160	1600	RKS1D560MCNAHHGS
		68	6.3×5.8	0.12	100	50	1900	900	RKS1D680MCNAFEFS
			6.3×7.7	0.12	100	30	2900	1400	RKS1D680MCNAFGGS
			8×6.7	0.12	100	30	3160	1600	RKS1D680MCNAHFGS
			8×7.7	0.12	100	30	3160	1600	RKS1D680MCNAHGGGS
			8×8.7	0.12	100	30	3160	1600	RKS1D680MCNAHHGS
		82	6.3×5.8	0.12	100	50	1900	900	RKS1D820MCNAFEFS
			6.3×7.7	0.12	100	30	2900	1400	RKS1D820MCNAFGGS
			8×6.7	0.12	100	30	3160	1600	RKS1D820MCNAHFGS
			8×7.7	0.12	100	30	3160	1600	RKS1D820MCNAHGGGS
			8×8.7	0.12	100	30	3160	1600	RKS1D820MCNAHHGS
		100	6.3×5.8	0.12	100	50	1900	900	RKS1D101MCNAFEFS
			6.3×7.7	0.12	100	30	2900	1400	RKS1D101MCNAFGGS
			8×6.7	0.12	100	30	3160	1600	RKS1D101MCNAHFGS
			8×7.7	0.12	100	30	3160	1600	RKS1D101MCNAHGGGS
			8×8.7	0.12	100	30	3160	1600	RKS1D101MCNAHHGS
		120	6.3×5.8	0.12	120	50	1900	900	RKS1D121MCNAFEFS
			6.3×7.7	0.12	120	30	2900	1400	RKS1D121MCNAFGGS
			8×6.7	0.12	120	30	3160	1600	RKS1D121MCNAHFGS
			8×7.7	0.12	120	30	3160	1600	RKS1D121MCNAHGGGS
			8×8.7	0.12	120	30	3160	1600	RKS1D121MCNAHHGS
		150	6.3×7.7	0.12	150	30	2900	1400	RKS1D151MCNAFGGS
			8×6.7	0.12	150	30	3160	1600	RKS1D151MCNAHFGS
			8×7.7	0.12	150	30	3160	1600	RKS1D151MCNAHGGGS
			8×8.7	0.12	150	30	3160	1600	RKS1D151MCNAHHGS
		180	6.3×7.7	0.12	180	30	2900	1400	RKS1D181MCNAFGGS
			8×6.7	0.12	180	30	3160	1600	RKS1D181MCNAHFGS
			8×7.7	0.12	180	30	3160	1600	RKS1D181MCNAHGGGS
			8×8.7	0.12	180	30	3160	1600	RKS1D181MCNAHHGS

(*4) Ambient temperature of a capacitor

RKS

■ Dimensions

Rated Voltage (V) (code)	Surge Voltage (V)	Rated Capacitance (μF)	Case Size φD×L (mm)	tan δ	Leakage Current (μA) (at 20°C after 2 minutes)	ESR (mΩ) (20°C/100kHz)	Rated Ripple Current (mA rms/100kHz)		Part Number
							≤105°C (*4)	105°C < ≤125°C (*4)	
20 (1D)	23	220	8×6.7	0.12	220	30	3160	1600	RKS1D221MCNAHFGS
			8×7.7	0.12	220	30	3160	1600	RKS1D221MCNAHGGS
			8×8.7	0.12	220	30	3160	1600	RKS1D221MCNAHHGS
		270	8×7.7	0.12	270	30	3160	1600	RKS1D271MCNAHGGS
			8×8.7	0.12	270	30	3160	1600	RKS1D271MCNAHHGS
			330	8×8.7	0.12	330	30	3160	1600
390	8×8.7	0.12	390	30	3160	1600	RKS1D391MCNAHHGS		
25 (1E)	28.7	8.2	6.3×5.8	0.12	100	50	1900	900	RKS1E8R2MCNAFEFGS
		10	6.3×5.8	0.12	100	50	1900	900	RKS1E100MCNAFEFGS
		12	6.3×5.8	0.12	100	50	1900	900	RKS1E120MCNAFEFGS
			6.3×7.7	0.12	100	30	2900	1400	RKS1E120MCNAFGGS
		15	6.3×5.8	0.12	100	50	1900	900	RKS1E150MCNAFEFGS
			6.3×7.7	0.12	100	30	2900	1400	RKS1E150MCNAFGGS
			8×6.7	0.12	100	30	3160	1600	RKS1E150MCNAHFGS
		18	6.3×5.8	0.12	100	50	1900	900	RKS1E180MCNAFEFGS
			6.3×7.7	0.12	100	30	2900	1400	RKS1E180MCNAFGGS
			8×6.7	0.12	100	30	3160	1600	RKS1E180MCNAHFGS
			8×7.7	0.12	100	30	3160	1600	RKS1E180MCNAHGGS
		22	6.3×5.8	0.12	100	50	1900	900	RKS1E220MCNAFEFGS
			6.3×7.7	0.12	100	30	2900	1400	RKS1E220MCNAFGGS
			8×6.7	0.12	100	30	3160	1600	RKS1E220MCNAHFGS
			8×7.7	0.12	100	30	3160	1600	RKS1E220MCNAHGGS
		27	8×8.7	0.12	100	30	3160	1600	RKS1E220MCNAHHGS
			6.3×5.8	0.12	100	50	1900	900	RKS1E270MCNAFEFGS
			6.3×7.7	0.12	100	30	2900	1400	RKS1E270MCNAFGGS
			8×6.7	0.12	100	30	3160	1600	RKS1E270MCNAHFGS
		33	8×7.7	0.12	100	30	3160	1600	RKS1E270MCNAHGGS
			8×8.7	0.12	100	30	3160	1600	RKS1E270MCNAHHGS
			6.3×5.8	0.12	100	50	1900	900	RKS1E330MCNAFEFGS
			6.3×7.7	0.12	100	30	2900	1400	RKS1E330MCNAFGGS
		39	8×6.7	0.12	100	30	3160	1600	RKS1E330MCNAHFGS
			8×7.7	0.12	100	30	3160	1600	RKS1E330MCNAHGGS
			8×8.7	0.12	100	30	3160	1600	RKS1E330MCNAHHGS
			6.3×5.8	0.12	100	50	1900	900	RKS1E390MCNAFEFGS
			6.3×7.7	0.12	100	30	2900	1400	RKS1E390MCNAFGGS
		47	8×6.7	0.12	100	30	3160	1600	RKS1E390MCNAHFGS
			8×7.7	0.12	100	30	3160	1600	RKS1E390MCNAHGGS
			8×8.7	0.12	100	30	3160	1600	RKS1E390MCNAHHGS
			6.3×5.8	0.12	100	50	1900	900	RKS1E470MCNAFEFGS
			6.3×7.7	0.12	100	30	2900	1400	RKS1E470MCNAFGGS
		56	8×6.7	0.12	100	30	3160	1600	RKS1E470MCNAHFGS
			8×7.7	0.12	100	30	3160	1600	RKS1E470MCNAHGGS
			8×8.7	0.12	100	30	3160	1600	RKS1E470MCNAHHGS
			6.3×5.8	0.12	100	50	1900	900	RKS1E560MCNAFEFGS
			6.3×7.7	0.12	100	30	2900	1400	RKS1E560MCNAFGGS
			8×6.7	0.12	100	30	3160	1600	RKS1E560MCNAHFGS
			8×7.7	0.12	100	30	3160	1600	RKS1E560MCNAHGGS
			8×8.7	0.12	100	30	3160	1600	RKS1E560MCNAHHGS

(*4) Ambient temperature of a capacitor

RKS

■ Dimensions

Rated Voltage (V) (code)	Surge Voltage (V)	Rated Capacitance (μF)	Case Size φD×L (mm)	tan δ	Leakage Current (μA) (at 20°C after 2 minutes)	ESR (mΩ) (20°C/100kHz)	Rated Ripple Current (mArms/100kHz)		Part Number
							≤105°C (*4)	105°C < ≤125°C (*4)	
25 (1E)	28.7	68	6.3×5.8	0.12	100	50	1900	900	RKS1E680MCNAFEFGS
			6.3×7.7	0.12	100	30	2900	1400	RKS1E680MCNAFGGS
			8×6.7	0.12	100	30	3160	1600	RKS1E680MCNAHFGS
			8×7.7	0.12	100	30	3160	1600	RKS1E680MCNAHGGGS
			8×8.7	0.12	100	30	3160	1600	RKS1E680MCNAHHGS
		82	6.3×5.8	0.12	102	50	1900	900	RKS1E820MCNAFEFGS
			6.3×7.7	0.12	102	30	2900	1400	RKS1E820MCNAFGGS
			8×6.7	0.12	102	30	3160	1600	RKS1E820MCNAHFGS
			8×7.7	0.12	102	30	3160	1600	RKS1E820MCNAHGGGS
			8×8.7	0.12	102	30	3160	1600	RKS1E820MCNAHHGS
		100	6.3×7.7	0.12	125	30	2900	1400	RKS1E101MCNAFGGS
			8×6.7	0.12	125	30	3160	1600	RKS1E101MCNAHFGS
			8×7.7	0.12	125	30	3160	1600	RKS1E101MCNAHGGGS
			8×8.7	0.12	125	30	3160	1600	RKS1E101MCNAHHGS
		120	6.3×7.7	0.12	150	30	2900	1400	RKS1E121MCNAFGGS
			8×6.7	0.12	150	30	3160	1600	RKS1E121MCNAHFGS
			8×7.7	0.12	150	30	3160	1600	RKS1E121MCNAHGGGS
			8×8.7	0.12	150	30	3160	1600	RKS1E121MCNAHHGS
		150	8×6.7	0.12	187	30	3160	1600	RKS1E151MCNAHFGS
			8×7.7	0.12	187	30	3160	1600	RKS1E151MCNAHGGGS
			8×8.7	0.12	187	30	3160	1600	RKS1E151MCNAHHGS
		180	8×7.7	0.12	225	30	3160	1600	RKS1E181MCNAHGGGS
			8×8.7	0.12	225	30	3160	1600	RKS1E181MCNAHHGS
		220	8×8.7	0.12	275	30	3160	1600	RKS1E221MCNAHHGS
35 (1V)	40.2	8.2	6.3×5.8	0.12	100	60	1900	900	RKS1V8R2MCNAFEFGS
		10	6.3×5.8	0.12	100	60	1900	900	RKS1V100MCNAFEFGS
		12	6.3×5.8	0.12	100	60	1900	900	RKS1V120MCNAFEFGS
			6.3×7.7	0.12	100	35	2900	1400	RKS1V120MCNAFGGS
		15	6.3×5.8	0.12	100	60	1900	900	RKS1V150MCNAFEFGS
			6.3×7.7	0.12	100	35	2900	1400	RKS1V150MCNAFGGS
			8×6.7	0.12	100	30	3160	1600	RKS1V150MCNAHFGS
		18	6.3×5.8	0.12	100	60	1900	900	RKS1V180MCNAFEFGS
			6.3×7.7	0.12	100	35	2900	1400	RKS1V180MCNAFGGS
			8×6.7	0.12	100	30	3160	1600	RKS1V180MCNAHFGS
			8×7.7	0.12	100	30	3160	1600	RKS1V180MCNAHGGGS
		22	6.3×5.8	0.12	100	60	1900	900	RKS1V220MCNAFEFGS
			6.3×7.7	0.12	100	35	2900	1400	RKS1V220MCNAFGGS
			8×6.7	0.12	100	30	3160	1600	RKS1V220MCNAHFGS
			8×7.7	0.12	100	30	3160	1600	RKS1V220MCNAHGGGS
			8×8.7	0.12	100	30	3160	1600	RKS1V220MCNAHHGS
		27	6.3×5.8	0.12	100	60	1900	900	RKS1V270MCNAFEFGS
			6.3×7.7	0.12	100	35	2900	1400	RKS1V270MCNAFGGS
			8×6.7	0.12	100	30	3160	1600	RKS1V270MCNAHFGS
			8×7.7	0.12	100	30	3160	1600	RKS1V270MCNAHGGGS
			8×8.7	0.12	100	30	3160	1600	RKS1V270MCNAHHGS
		33	6.3×5.8	0.12	100	60	1900	900	RKS1V330MCNAFEFGS
			6.3×7.7	0.12	100	35	2900	1400	RKS1V330MCNAFGGS
			8×6.7	0.12	100	30	3160	1600	RKS1V330MCNAHFGS
8×7.7	0.12		100	30	3160	1600	RKS1V330MCNAHGGGS		
8×8.7	0.12		100	30	3160	1600	RKS1V330MCNAHHGS		

(*4) Ambient temperature of a capacitor

RKS

■ Dimensions

Rated Voltage (V) (code)	Surge Voltage (V)	Rated Capacitance (μF)	Case Size φD×L (mm)	tan δ	Leakage Current (μA) (at 20°C after 2 minutes)	ESR (mΩ) (20°C/100kHz)	Rated Ripple Current (mArms/100kHz)		Part Number
							≤105°C (*4)	105°C < ≤125°C (*4)	
35 (1V)	40.2	39	6.3×5.8	0.12	100	60	1900	900	RKS1V390MCNAFEFS
			6.3×7.7	0.12	100	35	2900	1400	RKS1V390MCNAFGGS
			8×6.7	0.12	100	30	3160	1600	RKS1V390MCNAHFGS
			8×7.7	0.12	100	30	3160	1600	RKS1V390MCNAHGGGS
			8×8.7	0.12	100	30	3160	1600	RKS1V390MCNAHHGS
		47	6.3×5.8	0.12	100	60	1900	900	RKS1V470MCNAFEFS
			6.3×7.7	0.12	100	35	2900	1400	RKS1V470MCNAFGGS
			8×6.7	0.12	100	30	3160	1600	RKS1V470MCNAHFGS
			8×7.7	0.12	100	30	3160	1600	RKS1V470MCNAHGGGS
			8×8.7	0.12	100	30	3160	1600	RKS1V470MCNAHHGS
		56	6.3×7.7	0.12	100	35	2900	1400	RKS1V560MCNAFGGS
			8×6.7	0.12	100	30	3160	1600	RKS1V560MCNAHFGS
			8×7.7	0.12	100	30	3160	1600	RKS1V560MCNAHGGGS
		68	8×8.7	0.12	100	30	3160	1600	RKS1V560MCNAHHGS
			6.3×7.7	0.12	119	35	2900	1400	RKS1V680MCNAFGGS
			8×6.7	0.12	119	30	3160	1600	RKS1V680MCNAHFGS
		82	8×7.7	0.12	119	30	3160	1600	RKS1V680MCNAHGGGS
			8×8.7	0.12	119	30	3160	1600	RKS1V680MCNAHHGS
			8×7.7	0.12	143	30	3160	1600	RKS1V820MCNAHGGGS
		100	8×8.7	0.12	143	30	3160	1600	RKS1V820MCNAHHGS
			8×7.7	0.12	175	30	3160	1600	RKS1V101MCNAHGGGS
		120	8×8.7	0.12	175	30	3160	1600	RKS1V101MCNAHHGS
			8×8.7	0.12	210	30	3160	1600	RKS1V121MCNAHHGS
		50 (1H)	57.5	8.2	6.3×5.8	0.12	100	80	1600
6.3×5.8	0.12				100	80	1600	750	RKS1H100MCNAFEFS
10	6.3×5.8			0.12	100	80	1600	750	RKS1H120MCNAFEFS
	6.3×7.7			0.12	100	40	2280	1100	RKS1H120MCNAFGGS
12	6.3×5.8			0.12	100	80	1600	750	RKS1H150MCNAFEFS
	6.3×7.7			0.12	100	40	2280	1100	RKS1H150MCNAFGGS
	8×6.7			0.12	100	30	3160	1600	RKS1H150MCNAHFGS
15	6.3×5.8			0.12	100	80	1600	750	RKS1H180MCNAFEFS
	6.3×7.7			0.12	100	40	2280	1100	RKS1H180MCNAFGGS
	8×6.7			0.12	100	30	3160	1600	RKS1H180MCNAHFGS
	8×7.7			0.12	100	30	3160	1600	RKS1H180MCNAHGGGS
18	6.3×5.8			0.12	100	80	1600	750	RKS1H180MCNAFEFS
	6.3×7.7			0.12	100	40	2280	1100	RKS1H180MCNAFGGS
	8×6.7			0.12	100	30	3160	1600	RKS1H180MCNAHFGS
	8×7.7			0.12	100	30	3160	1600	RKS1H180MCNAHGGGS
22	6.3×5.8			0.12	100	80	1600	750	RKS1H220MCNAFEFS
	6.3×7.7			0.12	100	40	2280	1100	RKS1H220MCNAFGGS
	8×6.7			0.12	100	30	3160	1600	RKS1H220MCNAHFGS
	8×7.7			0.12	100	30	3160	1600	RKS1H220MCNAHGGGS
	8×8.7			0.12	100	30	3160	1600	RKS1H220MCNAHHGS
27	6.3×7.7			0.12	100	40	2280	1100	RKS1H270MCNAFGGS
	8×6.7			0.12	100	30	3160	1600	RKS1H270MCNAHFGS
	8×7.7			0.12	100	30	3160	1600	RKS1H270MCNAHGGGS
	8×8.7			0.12	100	30	3160	1600	RKS1H270MCNAHHGS
33	6.3×7.7	0.12	100	40	2280	1100	RKS1H330MCNAFGGS		
	8×6.7	0.12	100	30	3160	1600	RKS1H330MCNAHFGS		
	8×7.7	0.12	100	30	3160	1600	RKS1H330MCNAHGGGS		
	8×8.7	0.12	100	30	3160	1600	RKS1H330MCNAHHGS		

(*4) Ambient temperature of a capacitor

RKS

■ Dimensions

Rated Voltage (V) (code)	Surge Voltage (V)	Rated Capacitance (μF)	Case Size φD×L (mm)	tan δ	Leakage Current (μA) (at 20°C after 2 minutes)	ESR (mΩ) (20°C/100kHz)	Rated Ripple Current (mArms/100kHz)		Part Number
							≤105°C (*4)	105°C < ≤125°C (*4)	
50 (1H)	57.5	39	8×6.7	0.12	100	30	3160	1600	RKS1H390MCNAHFGS
			8×7.7	0.12	100	30	3160	1600	RKS1H390MCNAHGGS
			8×8.7	0.12	100	30	3160	1600	RKS1H390MCNAHHGS
		47	8×7.7	0.12	117	30	3160	1600	RKS1H470MCNAHFGS
			8×8.7	0.12	117	30	3160	1600	RKS1H470MCNAHHGS
		56	8×8.7	0.12	140	30	3160	1600	RKS1H560MCNAHHGS
63 (1J)	72.5	8.2	6.3×5.8	0.12	100	120	1500	700	RKS1J8R2MCNAFEFGS
			6.3×7.7	0.12	100	80	1860	900	RKS1J8R2MCNAFGGS
			8×6.7	0.12	100	40	2180	1100	RKS1J8R2MCNAHFGS
		10	6.3×5.8	0.12	100	120	1500	700	RKS1J100MCNAFEFGS
			6.3×7.7	0.12	100	80	1860	900	RKS1J100MCNAFGGS
			8×6.7	0.12	100	40	2180	1100	RKS1J100MCNAHFGS
		12	6.3×5.8	0.12	100	120	1500	700	RKS1J120MCNAFEFGS
			6.3×7.7	0.12	100	80	1860	900	RKS1J120MCNAFGGS
			8×6.7	0.12	100	40	2180	1100	RKS1J120MCNAHFGS
			8×7.7	0.12	100	40	2180	1100	RKS1J120MCNAHGGS
		15	6.3×5.8	0.12	100	120	1500	700	RKS1J150MCNAFEFGS
			6.3×7.7	0.12	100	80	1860	900	RKS1J150MCNAFGGS
			8×6.7	0.12	100	40	2180	1100	RKS1J150MCNAHFGS
			8×7.7	0.12	100	40	2180	1100	RKS1J150MCNAHGGS
			8×8.7	0.12	100	40	2180	1100	RKS1J150MCNAHHGS
		18	6.3×7.7	0.12	100	80	1860	900	RKS1J180MCNAFGGS
			8×6.7	0.12	100	40	2180	1100	RKS1J180MCNAHFGS
			8×7.7	0.12	100	40	2180	1100	RKS1J180MCNAHGGS
			8×8.7	0.12	100	40	2180	1100	RKS1J180MCNAHHGS
		22	6.3×7.7	0.12	100	80	1860	900	RKS1J220MCNAFGGS
			8×6.7	0.12	100	40	2180	1100	RKS1J220MCNAHFGS
			8×7.7	0.12	100	40	2180	1100	RKS1J220MCNAHGGS
			8×8.7	0.12	100	40	2180	1100	RKS1J220MCNAHHGS
		27	8×6.7	0.12	100	40	2180	1100	RKS1J270MCNAHFGS
			8×7.7	0.12	100	40	2180	1100	RKS1J270MCNAHGGS
			8×8.7	0.12	100	40	2180	1100	RKS1J270MCNAHHGS
		33	8×7.7	0.12	103	40	2180	1100	RKS1J330MCNAHGGS
			8×8.7	0.12	103	40	2180	1100	RKS1J330MCNAHHGS
		39	8×7.7	0.12	122	40	2180	1100	RKS1J390MCNAHGGS
			8×8.7	0.12	122	40	2180	1100	RKS1J390MCNAHHGS
		47	8×8.7	0.12	148	40	2180	1100	RKS1J470MCNAHHGS

(*4) Ambient temperature of a capacitor

■ Frequency Characteristics (The frequency characteristics are typical and not a guaranteed value.)

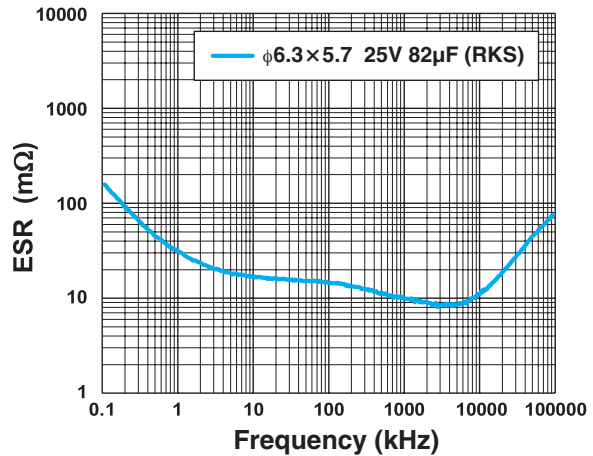
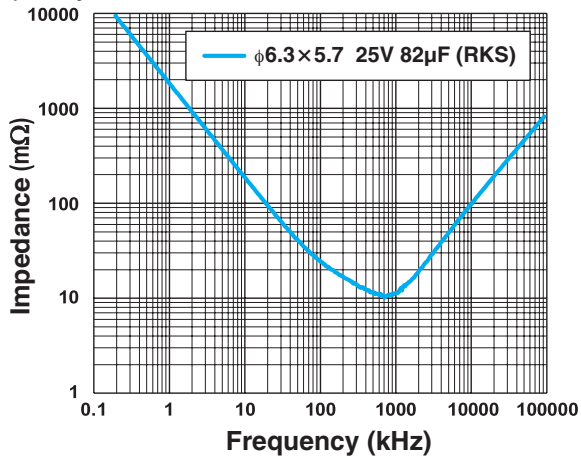

• For taping specifications, recommended land size/soldering by reflow and minimum order quantity, please refer to the Guidelines for Aluminum Electrolytic Capacitors.

RNS Standard



FPCAP



- Low ESR, High ripple current.
- Load life of 2000 hours at 105°C.
- Radial lead type : Lead free flow soldering condition correspondence.
- Compliant to the RoHS directive (2011/65/EU,(EU)2015/863).

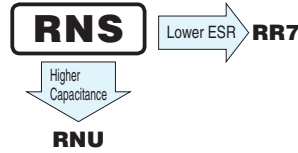

Specifications

Item	Performance Characteristics	
Category Temperature Range	-55 to +105°C	
Rated Voltage Range	4.0 to 25V	
Rated Capacitance Range	10 to 1200μF	
Capacitance Tolerance	±20% at 120Hz, 20°C	
Tangent of loss angle (tan δ)	Less than or equal to the specified value at 120Hz, 20°C	
ESR (※1)	Less than or equal to the specified value at 100kHz, 20°C	
Leakage Current (※2)	Less than or equal to the specified value. After 2 minutes' application of rated voltage at 20°C	
Endurance	Test condition	105°C, rated voltage 2000Hrs.
	Capacitance change	Within ±20% of initial value before test
	tan δ	150% or less than the initial specified value
	ESR(※1)	150% or less than the initial specified value
	Leakage current (※2)	Less than or equal to the initial specified value

※1 ESR should be measured at both of the terminal ends closest where the terminals protrude through the plastic platform.

※2 Conditioning : If any doubt arises, measure the leakage current after the voltage treatment of applying DC rated voltage continuously to the capacitor for 120 minutes at 105°C.

Dimensions

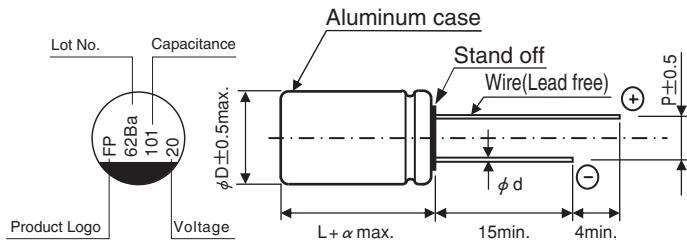

(mm)			
φD×L	φd	P	α
6.3×7	0.45	2.5	1.0
6.3×10	0.5	2.5	1.0
8×11.5	0.6	3.5	1.5
10×12.5	0.6	5.0	1.5

Frequency coefficient of rated ripple current

Frequency	120 Hz	1 kHz	10 kHz	100 kHz	300 kHz
Coefficient	0.10	0.45	0.50	1.00	1.00

Type numbering system (Example : 20V 100μF) Nichicon part number

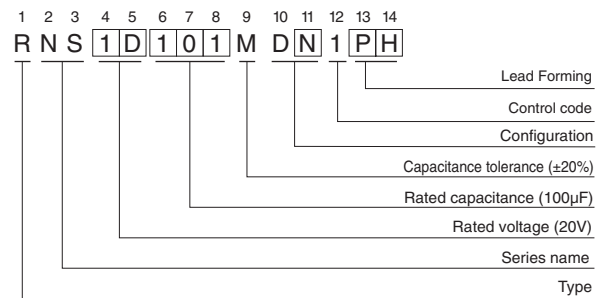

FPCAP part number

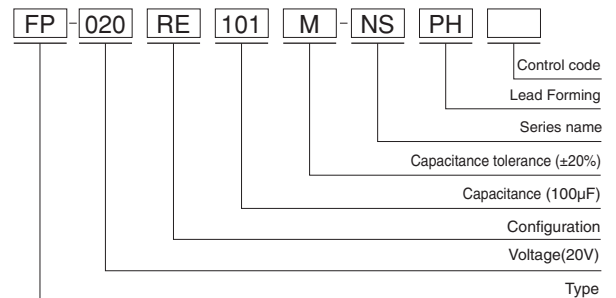

RNS

■ Dimensions

Rated Voltage (V) (code)	Surge Voltage (V)	Rated Capacitance (μF)	Case Size φD×L (mm)	tan δ	Leakage Current (μA) (at 20°C after 2 minutes)	ESR (mΩ) (20°C/100kHz)	Rated Ripple Current (mA _{rms}) (105°C/100kHz)	NICHICON	FPCAP
4.0 (0G)	4.6	560	8×11.5	0.08	336	10	5230	RNS0G561MDN1□□	FP-4R0RE561M-NS□□
		820	10×12.5	0.08	492	10	5500	RNS0G821MDN1□□	FP-4R0RE821M-NS□□
		1200	10×12.5	0.15	720	10	5500	RNS0G122MDN1□□	FP-4R0RE122M-NS□□
6.3 (0J)	7.2	47	6.3×7	0.07	50	42	2050	RNS0J470MDS1□□	FP-6R3RE470M-NS□□
		150	8×11.5	0.07	141	21	3900	RNS0J151MDN1□□	FP-6R3RE151M-NS□□
		220	8×11.5	0.07	207	21	3900	RNS0J221MDN1□□	FP-6R3RE221M-NS□□
		330	10×12.5	0.07	311	10	5500	RNS0J331MDN1□□	FP-6R3RE331M-NS□□
		390	8×11.5	0.08	368	10	5230	RNS0J391MDN1□□	FP-6R3RE391M-NS□□
		680	10×12.5	0.08	642	10	5500	RNS0J681MDN1□□	FP-6R3RE681M-NS□□
		820	10×12.5	0.12	774	10	5500	RNS0J821MDN1□□	FP-6R3RE821M-NS□□
1000	10×12.5	0.12	945	10	5500	RNS0J102MDN1□□	FP-6R3RE102M-NS□□		
10 (1A)	11.5	33	6.3×7	0.07	50	49	1900	RNS1A330MDS1□□	FP-010RE330M-NS□□
		68	6.3×10	0.07	102	35	2650	RNS1A680MDS1□□	FP-010RE680M-NS□□
		100	8×11.5	0.07	150	21	3900	RNS1A101MDN1□□	FP-010RE101M-NS□□
		220	10×12.5	0.07	330	10	5500	RNS1A221MDN1□□	FP-010RE221M-NS□□
		470	10×12.5	0.08	705	10	5500	RNS1A471MDN1□□	FP-010RE471M-NS□□
16 (1C)	18.4	22	6.3×7	0.06	52	49	1900	RNS1C220MDS1□□	FP-016RE220M-NS□□
		33	6.3×7	0.06	79	49	1900	RNS1C330MDS1□□	FP-016RE330M-NS□□
		47	6.3×10	0.06	112	42	2400	RNS1C470MDS1□□	FP-016RE470M-NS□□
		68	8×11.5	0.06	163	25	3600	RNS1C680MDN1□□	FP-016RE680M-NS□□
		100	8×11.5	0.06	240	21	3900	RNS1C101MDN1□□	FP-016RE101M-NS□□
		150	10×12.5	0.06	360	10	5500	RNS1C151MDN1□□	FP-016RE151M-NS□□
		180	8×11.5	0.08	432	16	4700	RNS1C181MDN1□□	FP-016RE181M-NS□□
330	10×12.5	0.08	792	10	5500	RNS1C331MDN1□□	FP-016RE331M-NS□□		
20 (1D)	23.0	15	6.3×7	0.06	50	63	1700	RNS1D150MDS1□□	FP-020RE150M-NS□□
		22	6.3×7	0.06	66	49	1900	RNS1D220MDS1□□	FP-020RE220M-NS□□
		33	6.3×10	0.06	99	49	2200	RNS1D330MDS1□□	FP-020RE330M-NS□□
		47	8×11.5	0.06	141	28	3400	RNS1D470MDN1□□	FP-020RE470M-NS□□
		68	8×11.5	0.06	204	25	3600	RNS1D680MDN1□□	FP-020RE680M-NS□□
		100	10×12.5	0.06	300	15	4500	RNS1D101MDN1□□	FP-020RE101M-NS□□
25 (1E)	28.7	10	6.3×7	0.06	50	63	1700	RNS1E100MDS1□□	FP-025RE100M-NS□□
		15	6.3×10	0.06	75	49	2200	RNS1E150MDS1□□	FP-025RE150M-NS□□
		22	8×11.5	0.06	110	28	3400	RNS1E220MDN1□□	FP-025RE220M-NS□□
		33	10×12.5	0.06	165	20	3800	RNS1E330MDN1□□	FP-025RE330M-NS□□
		47	10×12.5	0.06	235	20	3800	RNS1E470MDN1□□	FP-025RE470M-NS□□
		100	10×12.5	0.08	500	15	4500	RNS1E101MDN1□□	FP-025RE101M-NS□□

• For formed lead or taped product specifications and minimum order quantity, please refer to the Guidelines for Aluminum Electrolytic Capacitors.

RR7 Low ESR



- Ultra Low ESR, High ripple current.
- Load life of 2000 / 5000 hours at 105°C.
- Radial lead type : Lead free flow soldering condition correspondence.
- Compliant to the RoHS directive (2011/65/EU,(EU)2015/863).

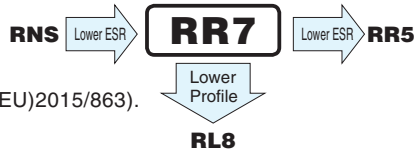

Specifications

Item	Performance Characteristics	
Category Temperature Range	-55 to +105°C	
Rated Voltage Range	2.5 to 16V	
Rated Capacitance Range	68 to 1500μF	
Capacitance Tolerance	±20% at 120Hz, 20°C	
Tangent of loss angle (tan δ)	Less than or equal to the specified value at 120Hz, 20°C	
ESR (※1)	Less than or equal to the specified value at 100kHz, 20°C	
Leakage Current (※2)	Less than or equal to the specified value. After 2 minutes' application of rated voltage at 20°C	
Endurance	Test condition	105°C, rated voltage 2000 / 5000Hrs.
	Capacitance change	Within ±20% of initial value before test
	tan δ	150% or less than the initial specified value
	ESR(※1)	150% or less than the initial specified value
	Leakage current (※2)	Less than or equal to the initial specified value

※1 ESR should be measured at both of the terminal ends closest to the capacitor body.
 ※2 Conditioning : If any doubt arises, measure the leakage current after the voltage treatment of applying DC rated voltage continuously to the capacitor for 120 minutes at 105°C.

Dimensions

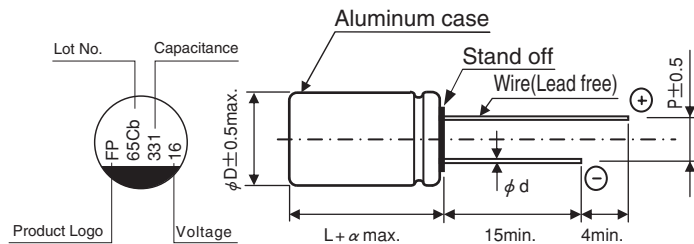

(mm)			
φD×L	φd	P	α
8×11.5	0.6	3.5	1.5
10×12.5	0.6	5.0	1.5

Type numbering system (Example : 16V 330μF) Nichicon part number

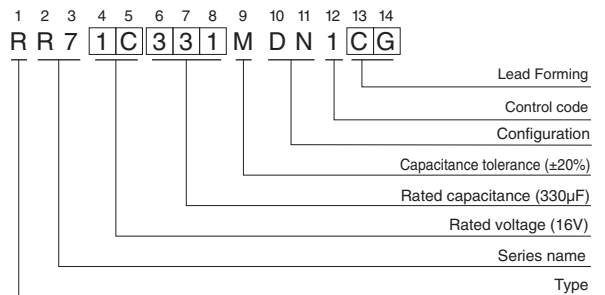

FPCAP part number

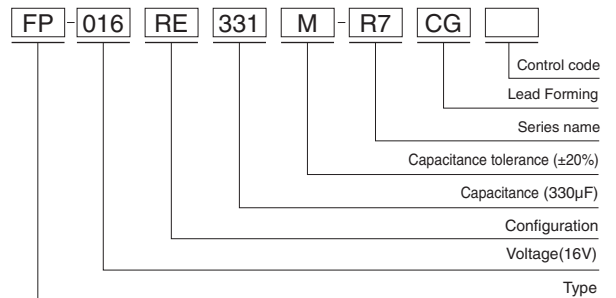

● Frequency coefficient of rated ripple current

Frequency	120 Hz	1 kHz	10 kHz	100 kHz	300 kHz
Coefficient	0.10	0.45	0.50	1.00	1.00

RR7

■ Dimensions

Rated Voltage (V) (code)	Surge Voltage (V)	Rated Capacitance (μF)	Case Size φD×L (mm)	tan δ	Leakage Current (μA) (at 20°C after 2 minutes)	ESR (mΩ) (20°C/100kHz)	Rated Ripple Current (mA _{rms}) (105°C/100kHz)	NICHICON	FPCAP
2.5 (0E)	2.8	680	8×11.5	0.08	425	7	5600	RR70E681MDN1□□	FP-2R5RE681M-R7□□
		820	8×11.5	0.08	512	7	5600	RR70E821MDN1□□	FP-2R5RE821M-R7□□
		1500	10×12.5	0.08	937	7	6100	RR70E152MDN1□□	FP-2R5RE152M-R7□□
4.0 (0G)	4.6	560	8×11.5	0.08	224	7	5600	RR70G561MDN1□□	FP-4R0RE561M-R7□□
		820	10×12.5	0.08	328	7	6100	RR70G821MDN1□□	FP-4R0RE821M-R7□□
		1200	10×12.5	0.15	960	7	6100	RR70G122MDN1□□	FP-4R0RE122M-R7□□
6.3 (0J)	7.2	150	8×11.5	0.07	47	7	5600	RR70J151MDN1□□	FP-6R3RE151M-R7□□
		220	8×11.5	0.07	69	7	5600	RR70J221MDN1□□	FP-6R3RE221M-R7□□
		330	10×12.5	0.07	103	7	6100	RR70J331MDN1□□	FP-6R3RE331M-R7□□
		390	8×11.5	0.08	245	7	5600	RR70J391MDN1□□	FP-6R3RE391M-R7□□
		680	10×12.5	0.08	428	7	6100	RR70J681MDN1□□	FP-6R3RE681M-R7□□
		820	10×12.5	0.12	516	7	6100	RR70J821MDN1□□	FP-6R3RE821M-R7□□
		1000	10×12.5	0.12	630	7	6100	RR70J102MDN1□□	FP-6R3RE102M-R7□□
10 (1A)	11.5	100	8×11.5	0.07	50	7	5600	RR71A101MDN1□□	FP-010RE101M-R7□□
		220	10×12.5	0.07	110	7	6100	RR71A221MDN1□□	FP-010RE221M-R7□□
		470	10×12.5	0.08	470	7	6100	RR71A471MDN1□□	FP-010RE471M-R7□□
		680	10×12.5	0.10	1360	7	6100	RR71A681MDN1□□	FP-010RE681M-R7□□
16 (1C)	18.4	68	8×11.5	0.06	54	7	5600	RR71C680MDN1□□	FP-016RE680M-R7□□
		100	8×11.5	0.06	80	7	5600	RR71C101MDN1□□	FP-016RE101M-R7□□
		150	10×12.5	0.06	120	7	6100	RR71C151MDN1□□	FP-016RE151M-R7□□
		270	10×12.5	0.08	648	7	6100	RR71C271MDN1□□	FP-016RE271M-R7□□
		330	10×12.5	0.08	792	7	6100	RR71C331MDN1□□	FP-016RE331M-R7□□
		*330	10×12.5	0.08	792	7	6100	RR71C331MDNASQ□□	FP-016RE331M-R7□□-5K

* : Load life 5000hours.

■ Frequency Characteristics (The frequency characteristics are typical and not a guaranteed value.)

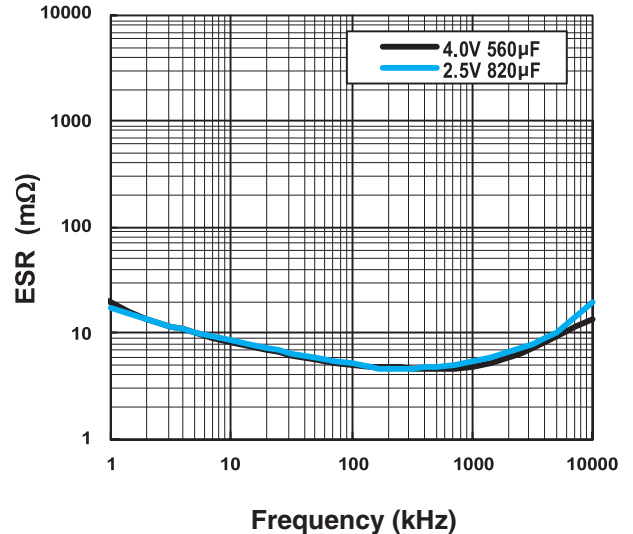
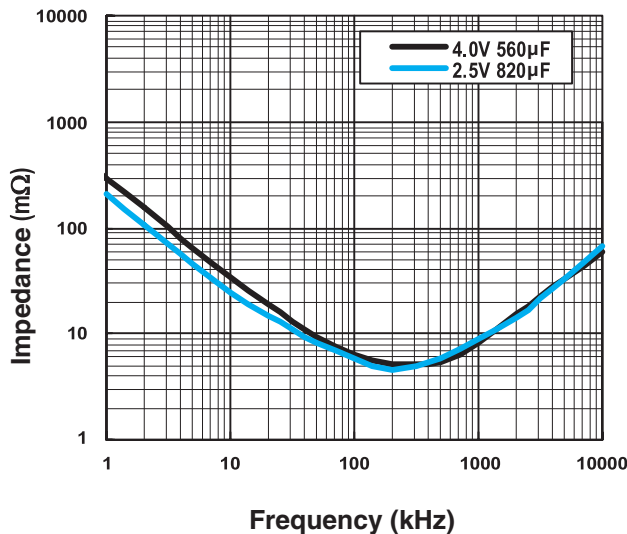

• For formed lead or taped product specifications and minimum order quantity, please refer to the Guidelines for Aluminum Electrolytic Capacitors.

RR5 Ultra-low ESR



FPCAP

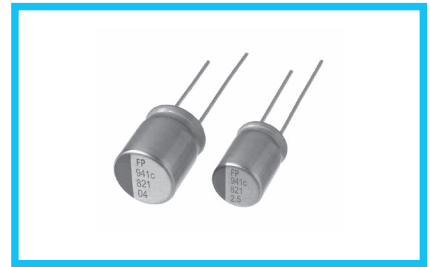

- Ultra Low ESR, High ripple current.
- Load life of 2000 hours at 105°C.
- Radial lead type : Lead free flow soldering condition correspondence.
- Compliant to the RoHS directive (2011/65/EU,(EU)2015/863).

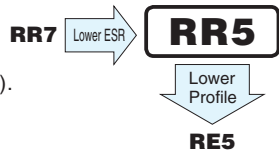

Specifications

Item	Performance Characteristics	
Category Temperature Range	-55 to +105°C	
Rated Voltage Range	2.5 to 6.3V	
Rated Capacitance Range	390 to 1500μF	
Capacitance Tolerance	±20% at 120Hz, 20°C	
Tangent of loss angle (tan δ)	Less than or equal to the specified value at 120Hz, 20°C	
ESR (※1)	Less than or equal to the specified value at 100kHz, 20°C	
Leakage Current (※2)	Less than or equal to the specified value. After 2 minutes' application of rated voltage at 20°C	
Endurance	Test condition	105°C, rated voltage 2000Hrs.
	Capacitance change	Within ±20% of initial value before test
	tan δ	150% or less than the initial specified value
	ESR(※1)	150% or less than the initial specified value
	Leakage current (※2)	Less than or equal to the initial specified value

※1 ESR should be measured at both of the terminal ends closest to the capacitor body.

※2 Conditioning : If any doubt arises, measure the leakage current after the voltage treatment of applying DC rated voltage continuously to the capacitor for 120 minutes at 105°C.

Dimensions

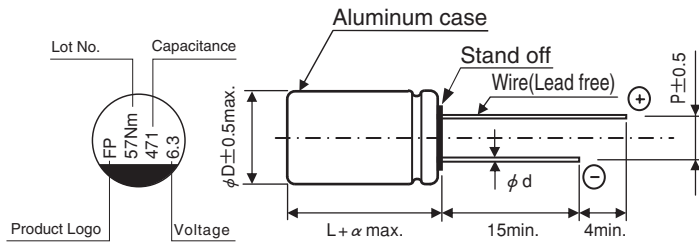

φD×L	φd	P	α
8×11.5	0.6	3.5	1.5
10×12.5	0.6	5.0	1.5

Frequency coefficient of rated ripple current

Frequency	120 Hz	1 kHz	10 kHz	100 kHz	300 kHz
Coefficient	0.10	0.45	0.50	1.00	1.00

Type numbering system (Example : 6.3V 470μF) Nichicon part number

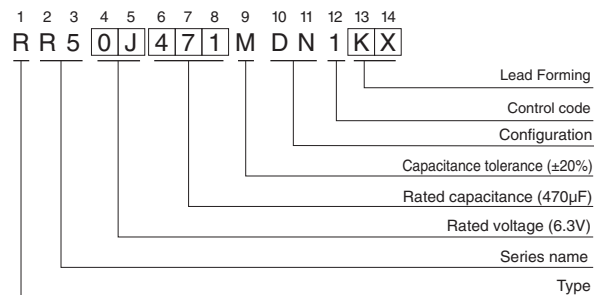

FPCAP part number

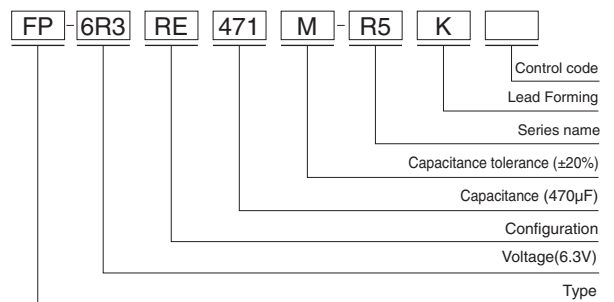

RR5

■ Dimensions

Rated Voltage (V) (code)	Surge Voltage (V)	Rated Capacitance (μF)	Case Size φD×L (mm)	tan δ	Leakage Current (μA) (at 20°C after 2 minutes)	ESR (mΩ) (20°C/100kHz)	Rated Ripple Current (mA _{rms}) (105°C/100kHz)	NICHICON	FPCAP
2.5 (0E)	2.8	560	8×11.5	0.15	350	5	6630	RR50E561MDN1□□	FP-2R5RE561M-R5□□
		680	8×11.5	0.15	425	5	6630	RR50E681MDN1□□	FP-2R5RE681M-R5□□
		820	8×11.5	0.15	512	5	6630	RR50E821MDN1□□	FP-2R5RE821M-R5□□
		1000	8×11.5	0.15	625	5	6630	RR50E102MDN1□□	FP-2R5RE102M-R5□□
		1500	10×12.5	0.15	937	5	7220	RR50E152MDN1□□	FP-2R5RE152M-R5□□
4.0 (0G)	4.6	560	8×11.5	0.15	560	5	6630	RR50G561MDN1□□	FP-4R0RE561M-R5□□
		820	10×12.5	0.15	820	5	7220	RR50G821MDN1□□	FP-4R0RE821M-R5□□
		1200	10×12.5	0.15	1200	5	7220	RR50G122MDN1□□	FP-4R0RE122M-R5□□
6.3 (0J)	7.2	390	8×11.5	0.15	614	5	6630	RR50J391MDN1□□	FP-6R3RE391M-R5□□
		470	8×11.5	0.15	592	5	6630	RR50J471MDN1□□	FP-6R3RE471M-R5□□
		680	10×12.5	0.15	1071	5	7220	RR50J681MDN1□□	FP-6R3RE681M-R5□□
		820	10×12.5	0.15	1291	5	7220	RR50J821MDN1□□	FP-6R3RE821M-R5□□

■ Frequency Characteristics (The frequency characteristics are typical and not a guaranteed value.)

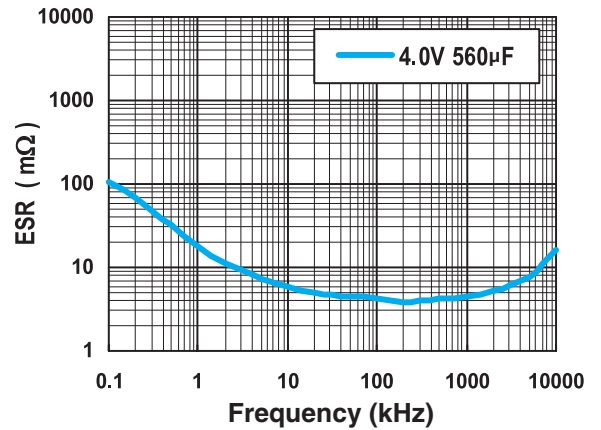
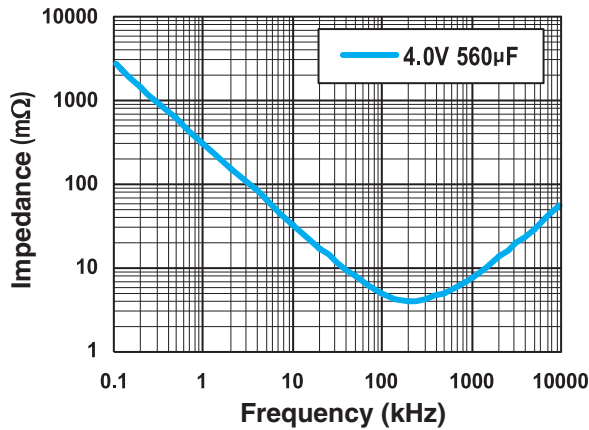

• For formed lead or taped product specifications and minimum order quantity, please refer to the Guidelines for Aluminum Electrolytic Capacitors.

RL8 Low ESR, Low Profile (φ8)



FPCAP Expanded

- Ultra Low ESR, High ripple current.
- Low Profile(Height 8mm).
- Load life of 2000/5000 hours at 105°C.
- Radial lead type : Lead free flow soldering condition correspondence.
- Compliant to the RoHS directive (2011/65/EU,(EU)2015/863).

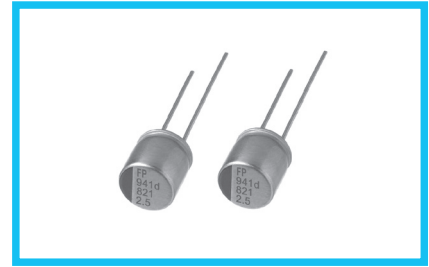
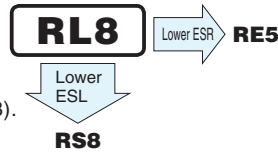

■ Specifications

Item	Performance Characteristics	
Category Temperature Range	-55 to +105°C	
Rated Voltage Range	2.5 to 35V	
Rated Capacitance Range	100 to 1500μF	
Capacitance Tolerance	±20% at 120Hz, 20°C	
Tangent of loss angle (tan δ)	Less than or equal to the specified value at 120Hz, 20°C	
ESR (※1)	Less than or equal to the specified value at 100kHz, 20°C	
Leakage Current (※2)	Less than or equal to the specified value. After 2 minutes' application of rated voltage at 20°C	
Endurance	Test condition	105°C, rated voltage 2000 / 5000Hrs.
	Capacitance change	Within ±20% of initial value before test
	tan δ	150% or less than the initial specified value
	ESR(※1)	150% or less than the initial specified value
	Leakage current (※2)	Less than or equal to the initial specified value

※1 ESR should be measured at both of the terminal ends closest to the capacitor body.

※2 Conditioning : If any doubt arises, measure the leakage current after the voltage treatment of applying DC rated voltage continuously to the capacitor for 120 minutes at 105°C.

■ Dimensions

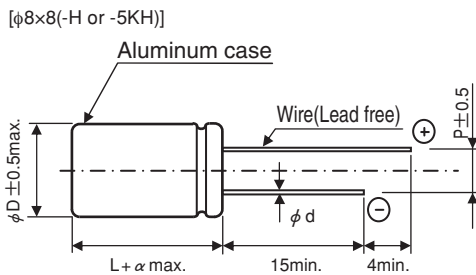
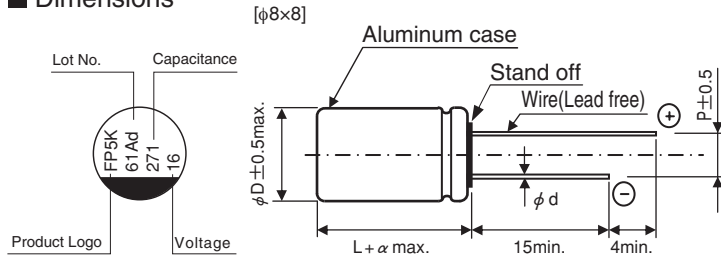

(mm)			
φD×L	φd	P	α
8×8	0.6	3.5	1.0

● Frequency coefficient of rated ripple current

Frequency	120 Hz	1 kHz	10 kHz	100 kHz	300 kHz
Coefficient	0.10	0.45	0.50	1.00	1.00

Type numbering system (Example : 16V 270μF)
Nichicon part number

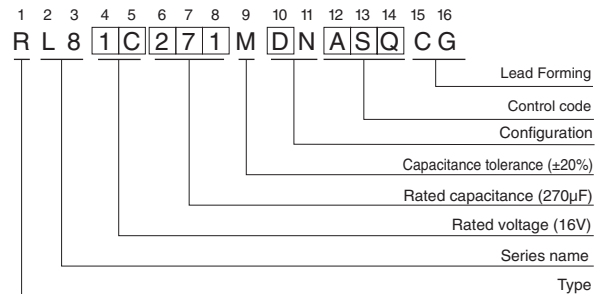

FPCAP part number

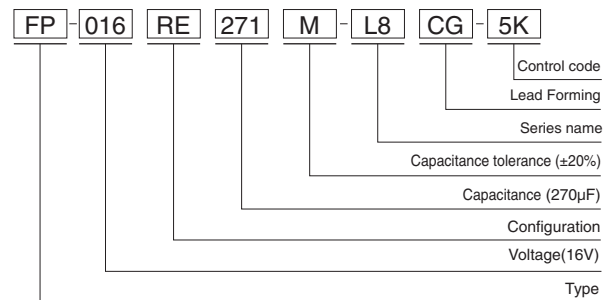

RL8

■ Dimensions

Rated Voltage (V) (code)	Surge Voltage (V)	Rated Capacitance (μF)	Case Size φD×L (mm)	tan δ	Leakage Current (μA) (at 20°C after 2 minutes)	ESR (mΩ) (20°C/100kHz)	Rated Ripple Current (mA rms) (105°C/100kHz)	NICHICON	FPCAP
2.5 (0E)	2.8	560	8×8	0.12	500	6	6100	RL80E561MDN1□□	FP-2R5RE561M-L8□□
		560	8×8	0.12	500	6	6100	RL80E561MCN1□□	FP-2R5RE561M-L8□□-H
		* 560	8×8	0.12	500	6	6100	RL80E561MDNASQ□□	FP-2R5RE561M-L8□□-5K
		* 560	8×8	0.12	500	6	6100	RL80E561MCNASQ□□	FP-2R5RE561M-L8□□-5KH
		820	8×8	0.12	512	6	6100	RL80E821MDN1□□	FP-2R5RE821M-L8□□
		820	8×8	0.12	512	6	6100	RL80E821MCN1□□	FP-2R5RE821M-L8□□-H
		* 820	8×8	0.12	512	6	6100	RL80E821MDNASQ□□	FP-2R5RE821M-L8□□-5K
		* 820	8×8	0.12	512	6	6100	RL80E821MCNASQ□□	FP-2R5RE821M-L8□□-5KH
		1000	8×8	0.12	625	6	6100	RL80E102MDN1□□	FP-2R5RE102M-L8□□
		1000	8×8	0.12	625	6	6100	RL80E102MCN1□□	FP-2R5RE102M-L8□□-H
		* 1000	8×8	0.12	625	6	6100	RL80E102MDNASQ□□	FP-2R5RE102M-L8□□-5K
		* 1000	8×8	0.12	625	6	6100	RL80E102MCNASQ□□	FP-2R5RE102M-L8□□-5KH
		1200	8×8	0.12	750	7	6100	RL80E122MDN1□□	FP-2R5RE122M-L8□□
		1200	8×8	0.12	750	7	6100	RL80E122MCN1□□	FP-2R5RE122M-L8□□-H
		* 1200	8×8	0.12	750	7	6100	RL80E122MDNASQ□□	FP-2R5RE122M-L8□□-5K
		* 1200	8×8	0.12	750	7	6100	RL80E122MCNASQ□□	FP-2R5RE122M-L8□□-5KH
		1500	8×8	0.12	937	7	6100	RL80E152MDN1□□	FP-2R5RE152M-L8□□
		1500	8×8	0.12	937	7	6100	RL80E152MCN1□□	FP-2R5RE152M-L8□□-H
* 1500	8×8	0.12	937	7	6100	RL80E152MDNASQ□□	FP-2R5RE152M-L8□□-5K		
* 1500	8×8	0.12	937	7	6100	RL80E152MCNASQ□□	FP-2R5RE152M-L8□□-5KH		
4.0 (0G)	4.6	560	8×8	0.12	560	6	6100	RL80G561MDN1□□	FP-4R0RE561M-L8□□
		560	8×8	0.12	560	6	6100	RL80G561MCN1□□	FP-4R0RE561M-L8□□-H
		* 560	8×8	0.12	560	6	6100	RL80G561MDNASQ□□	FP-4R0RE561M-L8□□-5K
		* 560	8×8	0.12	560	6	6100	RL80G561MCNASQ□□	FP-4R0RE561M-L8□□-5KH
		820	8×8	0.12	820	6	6100	RL80G821MDN1□□	FP-4R0RE821M-L8□□
		820	8×8	0.12	820	6	6100	RL80G821MCN1□□	FP-4R0RE821M-L8□□-H
		* 820	8×8	0.12	820	6	6100	RL80G821MDNASQ□□	FP-4R0RE821M-L8□□-5K
		* 820	8×8	0.12	820	6	6100	RL80G821MCNASQ□□	FP-4R0RE821M-L8□□-5KH
6.3 (0J)	7.2	470	8×8	0.12	592	8	5700	RL80J471MDN1□□	FP-6R3RE471M-L8□□
		470	8×8	0.12	592	8	5700	RL80J471MCN1□□	FP-6R3RE471M-L8□□-H
		* 470	8×8	0.12	592	8	5700	RL80J471MDNASQ□□	FP-6R3RE471M-L8□□-5K
		* 470	8×8	0.12	592	8	5700	RL80J471MCNASQ□□	FP-6R3RE471M-L8□□-5KH
		560	8×8	0.12	705	8	5700	RL80J561MDN1□□	FP-6R3RE561M-L8□□
		560	8×8	0.12	705	8	5700	RL80J561MCN1□□	FP-6R3RE561M-L8□□-H
		* 560	8×8	0.12	705	8	5700	RL80J561MDNASQ□□	FP-6R3RE561M-L8□□-5K
		* 560	8×8	0.12	705	8	5700	RL80J561MCNASQ□□	FP-6R3RE561M-L8□□-5KH
		680	8×8	0.12	856	8	5700	RL80J681MDN1□□	FP-6R3RE681M-L8□□
		680	8×8	0.12	856	8	5700	RL80J681MCN1□□	FP-6R3RE681M-L8□□-H
		* 680	8×8	0.12	856	8	5700	RL80J681MDNASQ□□	FP-6R3RE681M-L8□□-5K
		* 680	8×8	0.12	856	8	5700	RL80J681MCNASQ□□	FP-6R3RE681M-L8□□-5KH
		820	8×8	0.12	1033	8	5700	RL80J821MDN1□□	FP-6R3RE821M-L8□□
		820	8×8	0.12	1033	8	5700	RL80J821MCN1□□	FP-6R3RE821M-L8□□-H
		* 820	8×8	0.12	1033	8	5700	RL80J821MDNASQ□□	FP-6R3RE821M-L8□□-5K
		* 820	8×8	0.12	1033	8	5700	RL80J821MCNASQ□□	FP-6R3RE821M-L8□□-5KH
		1000	8×8	0.12	1260	9	5700	RL80J102MDN1□□	FP-6R3RE102M-L8□□
		1000	8×8	0.12	1260	9	5700	RL80J102MCN1□□	FP-6R3RE102M-L8□□-H
* 1000	8×8	0.12	1260	9	5700	RL80J102MDNASQ□□	FP-6R3RE102M-L8□□-5K		
* 1000	8×8	0.12	1260	9	5700	RL80J102MCNASQ□□	FP-6R3RE102M-L8□□-5KH		

RL8

■ Dimensions

Rated Voltage (V) (code)	Surge Voltage (V)	Rated Capacitance (μF)	Case Size φD×L (mm)	tan δ	Leakage Current (μA) (at 20°C after 2 minutes)	ESR (mΩ) (20°C/100kHz)	Rated Ripple Current (mA) (105°C/100kHz)	NICHICON	FPCAP
16 (1C)	18.4	100	8×8	0.12	320	12	5000	RL81C101MDN1□□	FP-016RE101M-L8□□
		100	8×8	0.12	320	12	5000	RL81C101MCN1□□	FP-016RE101M-L8□□-H
		* 100	8×8	0.12	320	12	5000	RL81C101MDNASQ□□	FP-016RE101M-L8□□-5K
		* 100	8×8	0.12	320	12	5000	RL81C101MCNASQ□□	FP-016RE101M-L8□□-5KH
		180	8×8	0.12	576	12	5000	RL81C181MDN1□□	FP-016RE181M-L8□□
		180	8×8	0.12	576	12	5000	RL81C181MCN1□□	FP-016RE181M-L8□□-H
		* 180	8×8	0.12	576	12	5000	RL81C181MDNASQ□□	FP-016RE181M-L8□□-5K
		* 180	8×8	0.12	576	12	5000	RL81C181MCNASQ□□	FP-016RE181M-L8□□-5KH
		220	8×8	0.12	704	12	5000	RL81C221MDN1□□	FP-016RE221M-L8□□
		220	8×8	0.12	704	12	5000	RL81C221MCN1□□	FP-016RE221M-L8□□-H
		* 220	8×8	0.12	704	12	5000	RL81C221MDNASQ□□	FP-016RE221M-L8□□-5K
		* 220	8×8	0.12	704	12	5000	RL81C221MCNASQ□□	FP-016RE221M-L8□□-5KH
		270	8×8	0.12	864	10	5000	RL81C271MDN1□□	FP-016RE271M-L8□□
		270	8×8	0.12	864	10	5000	RL81C271MCN1□□	FP-016RE271M-L8□□-H
		* 270	8×8	0.12	864	10	5000	RL81C271MDNASQ□□	FP-016RE271M-L8□□-5K
		* 270	8×8	0.12	864	10	5000	RL81C271MCNASQ□□	FP-016RE271M-L8□□-5KH
		330	8×8	0.12	1056	12	5000	RL81C331MDN1□□	FP-016RE331M-L8□□
		330	8×8	0.12	1056	12	5000	RL81C331MCN1□□	FP-016RE331M-L8□□-H
		* 330	8×8	0.12	1056	12	5000	RL81C331MDNASQ□□	FP-016RE331M-L8□□-5K
		* 330	8×8	0.12	1056	12	5000	RL81C331MCNASQ□□	FP-016RE331M-L8□□-5KH
470	8×8	0.12	1504	16	4000	RL81C471MDN1□□	FP-016RE471M-L8□□		
470	8×8	0.12	1504	16	4000	RL81C471MCN1□□	FP-016RE471M-L8□□-H		
* 470	8×8	0.12	1504	16	4000	RL81C471MDNASQ□□	FP-016RE471M-L8□□-5K		
* 470	8×8	0.12	1504	16	4000	RL81C471MCNASQ□□	FP-016RE471M-L8□□-5KH		
20 (1D)	23.0	* 330	8×8	0.12	1320	17	3880	RL81D331MCNASQ□□	FP-020RE331M-L8□□-5KH
35 (1V)	40.2	100	8×8	0.12	700	25	3000	RL81V101MDN1□□	FP-035RE101M-L8□□
		100	8×8	0.12	700	25	3000	RL81V101MCN1□□	FP-035RE101M-L8□□-H

* : Load life 5000hours.

Blue : New product (as of October 2023)

■ Frequency Characteristics (The frequency characteristics are typical and not a guaranteed value.)

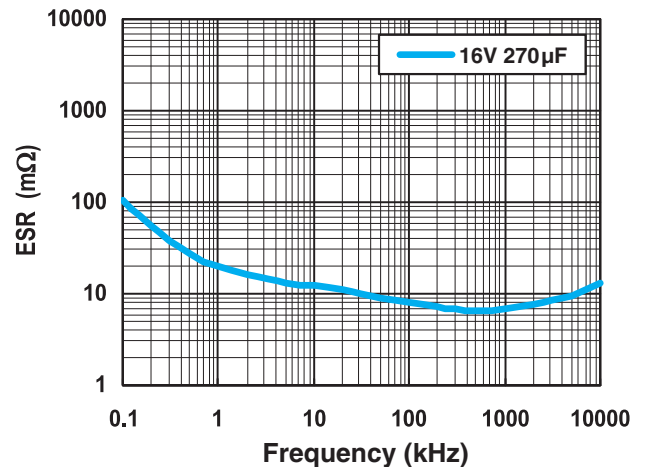
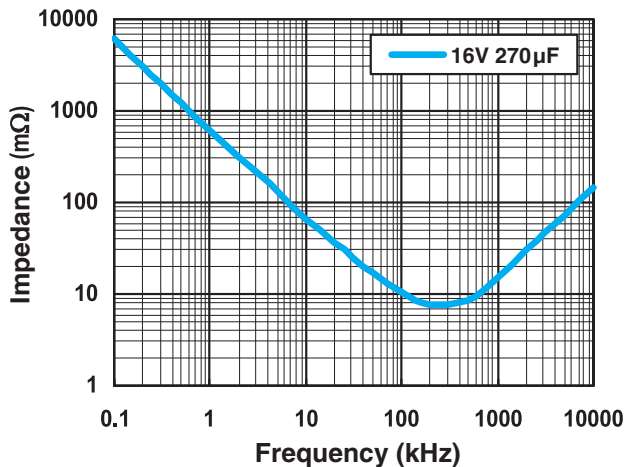

• For formed lead or taped product specifications and minimum order quantity, please refer to the Guidelines for Aluminum Electrolytic Capacitors.

RE5 Ultra-low ESR, Low Profile ($\phi 8$)



- Ultra Low ESR, High ripple current.
- Low Profile(Height 8mm).
- Load life of 2000 hours at 105°C.
- Radial lead type : Lead free flow soldering condition correspondence.
- Compliant to the RoHS directive (2011/65/EU,(EU)2015/863).

FPCAP

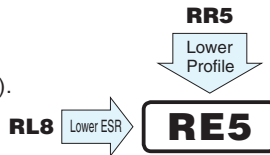

Specifications

Item	Performance Characteristics	
Category Temperature Range	-55 to +105°C	
Rated Voltage Range	2.5 to 4.0V	
Rated Capacitance Range	560 to 820 μ F	
Capacitance Tolerance	$\pm 20\%$ at 120Hz, 20°C	
Tangent of loss angle (tan δ)	Less than or equal to the specified value at 120Hz, 20°C	
ESR ($\ast 1$)	Less than or equal to the specified value at 100kHz, 20°C	
Leakage Current ($\ast 2$)	Less than or equal to the specified value. After 2 minutes' application of rated voltage at 20°C	
Endurance	Test condition	105°C, rated voltage 2000Hrs.
	Capacitance change	Within $\pm 20\%$ of initial value before test
	tan δ	150% or less than the initial specified value
	ESR($\ast 1$)	150% or less than the initial specified value
	Leakage current ($\ast 2$)	Less than or equal to the initial specified value

$\ast 1$ ESR should be measured at both of the terminal ends closest to the capacitor body.

$\ast 2$ Conditioning : If any doubt arises, measure the leakage current after the voltage treatment of applying DC rated voltage continuously to the capacitor for 120 minutes at 105°C.

Dimensions

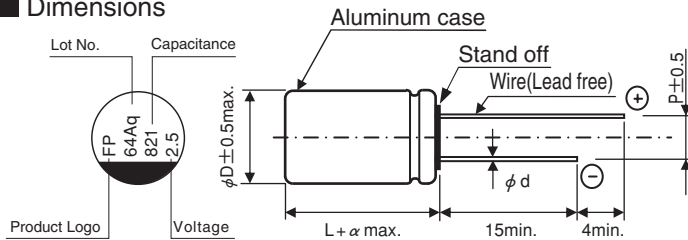

$\phi D \times L$	ϕd	P	α
8x8	0.6	3.5	1.0

(mm)

Type numbering system (Example : 2.5V 820 μ F) Nichicon part number

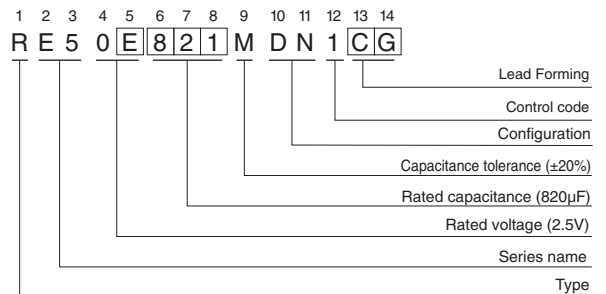

Frequency coefficient of rated ripple current

Frequency	120 Hz	1 kHz	10 kHz	100 kHz	300 kHz
Coefficient	0.10	0.45	0.50	1.00	1.00

FPCAP part number

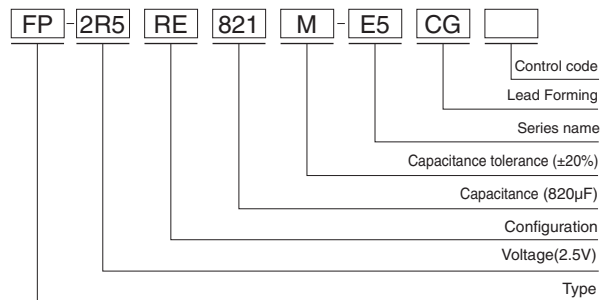

RE5

■ Dimensions

Rated Voltage (V) (code)	Surge Voltage (V)	Rated Capacitance (μF)	Case Size φD×L (mm)	tan δ	Leakage Current (μA) (at 20°C after 2 minutes)	ESR (mΩ) (20°C/100kHz)	Rated Ripple Current (mA _{rms}) (105°C/100kHz)	NICHICON	FPCAP
2.5 (0E)	2.8	560	8×8	0.10	500	5	6300	RE50E561MDN1□□	FP-2R5RE561M-E5□□
		820	8×8	0.10	512	5	6300	RE50E821MDN1□□	FP-2R5RE821M-E5□□
4.0 (0G)	4.6	560	8×8	0.10	560	5	6300	RE50G561MDN1□□	FP-4R0RE561M-E5□□

■ Frequency Characteristics (The frequency characteristics are typical and not a guaranteed value.)

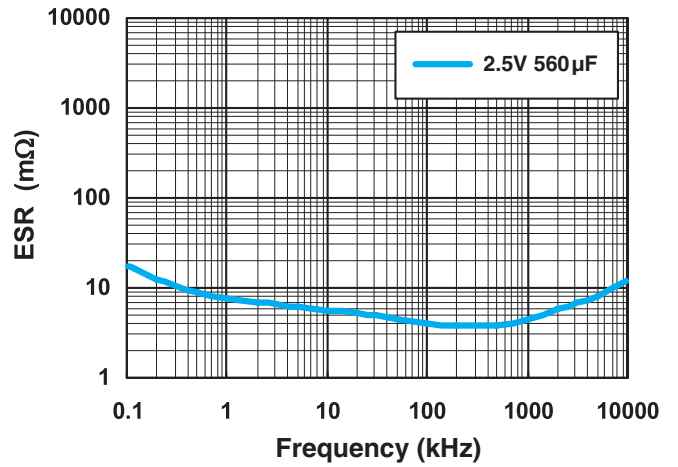
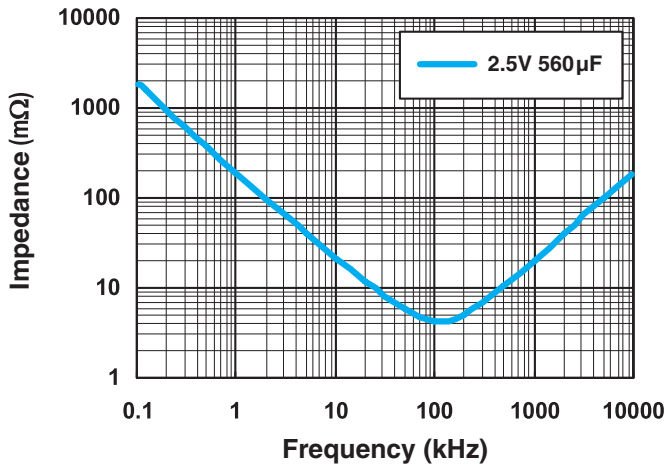

• For formed lead or taped product specifications and minimum order quantity, please refer to the Guidelines for Aluminum Electrolytic Capacitors.

RS8 Low ESR / ESL, Low Profile (φ6.3)

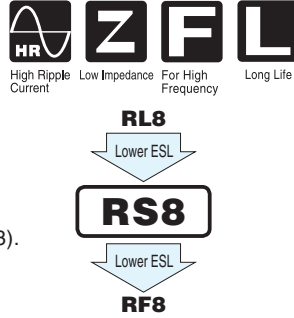

- Low ESR/ESL, High ripple current.
- Low Profile(Height 8mm).
- Load life of 2000/5000 hours at 105°C.
- Radial lead type : Lead free flow soldering condition correspondence.
- Compliant to the RoHS directive (2011/65/EU,(EU)2015/863).

FPCAP



■ Specifications

Item	Performance Characteristics	
Category Temperature Range	-55 to +105°C	
Rated Voltage Range	2.5 to 25V	
Rated Capacitance Range	56 to 1200μF	
Capacitance Tolerance	±20% at 120Hz, 20°C	
Tangent of loss angle (tan δ)	Less than or equal to the specified value at 120Hz, 20°C	
ESR (※1)	Less than or equal to the specified value at 100kHz, 20°C	
Leakage Current (※2)	Less than or equal to the specified value. After 2 minutes' application of rated voltage at 20°C	
Endurance	Test condition	105°C, rated voltage 2000 / 5000Hrs.
	Capacitance change	Within ±20% of initial value before test
	tan δ	150% or less than the initial specified value
	ESR(※1)	150% or less than the initial specified value
	Leakage current (※2)	Less than or equal to the initial specified value

※1 ESR should be measured at both of the terminal ends closest to the capacitor body.

※2 Conditioning : If any doubt arises, measure the leakage current after the voltage treatment of applying DC rated voltage continuously to the capacitor for 120 minutes at 105°C.

■ Dimensions

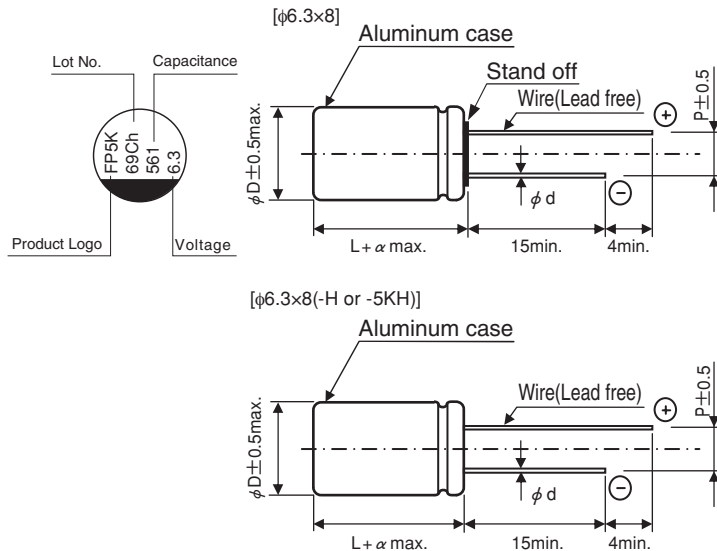

φD×L	φd	P	α
6.3×8	0.6	2.5	1.0

● Frequency coefficient of rated ripple current

Frequency	120 Hz	1 kHz	10 kHz	100 kHz	300 kHz
Coefficient	0.10	0.45	0.50	1.00	1.00

Type numbering system (Example : 6.3V 560μF)
Nichicon part number

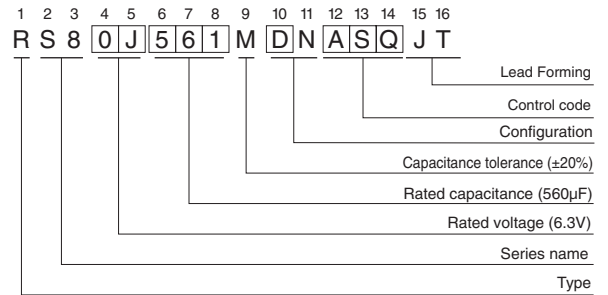

FPCAP part number

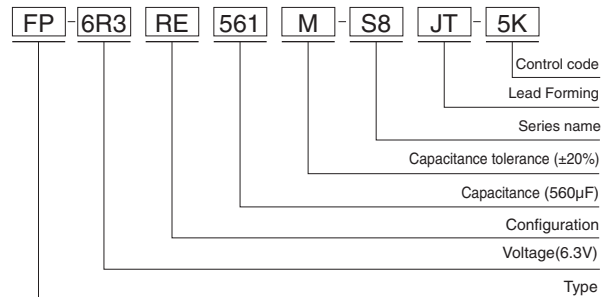

RS8

■ Dimensions

Rated Voltage (V) (code)	Surge Voltage (V)	Rated Capacitance (μF)	Case Size φD×L (mm)	tan δ	Leakage Current (μA) (at 20°C after 2 minutes)	ESR (mΩ) (20°C/100kHz)	ESL (Typ.) (nH, 40MHz)	Rated Ripple Current (mA rms) (105°C/100kHz)	NICHICON	FPCAP
2.5 (0E)	2.8	330	6.3×8	0.10	500	7	2	5600	RS80E331MDN1□□	FP-2R5RE331M-S8□□
		330	6.3×8	0.10	500	7	2	5600	RS80E331MCN1□□	FP-2R5RE331M-S8□□-H
		* 330	6.3×8	0.10	500	7	2	5600	RS80E331MDNASQ□□	FP-2R5RE331M-S8□□-5K
		* 330	6.3×8	0.10	500	7	2	5600	RS80E331MCNASQ□□	FP-2R5RE331M-S8□□-5KH
		470	6.3×8	0.10	500	7	2	5600	RS80E471MDN1□□	FP-2R5RE471M-S8□□
		470	6.3×8	0.10	500	7	2	5600	RS80E471MCN1□□	FP-2R5RE471M-S8□□-H
		* 470	6.3×8	0.10	500	7	2	5600	RS80E471MDNASQ□□	FP-2R5RE471M-S8□□-5K
		* 470	6.3×8	0.10	500	7	2	5600	RS80E471MCNASQ□□	FP-2R5RE471M-S8□□-5KH
		560	6.3×8	0.10	500	7	2	5600	RS80E561MDN1□□	FP-2R5RE561M-S8□□
		560	6.3×8	0.10	500	7	2	5600	RS80E561MCN1□□	FP-2R5RE561M-S8□□-H
		* 560	6.3×8	0.10	500	7	2	5600	RS80E561MDNASQ□□	FP-2R5RE561M-S8□□-5K
		* 560	6.3×8	0.10	500	7	2	5600	RS80E561MCNASQ□□	FP-2R5RE561M-S8□□-5KH
		820	6.3×8	0.10	512	7	2	5600	RS80E821MDN1□□	FP-2R5RE821M-S8□□
		820	6.3×8	0.10	512	7	2	5600	RS80E821MCN1□□	FP-2R5RE821M-S8□□-H
		* 820	6.3×8	0.10	512	7	2	5600	RS80E821MDNASQ□□	FP-2R5RE821M-S8□□-5K
		* 820	6.3×8	0.10	512	7	2	5600	RS80E821MCNASQ□□	FP-2R5RE821M-S8□□-5KH
1200	6.3×8	0.10	750	7	2	5600	RS80E122MDN1□□	FP-2R5RE122M-S8□□		
1200	6.3×8	0.10	750	7	2	5600	RS80E122MCN1□□	FP-2R5RE122M-S8□□-H		
4.0 (0G)	4.6	560	6.3×8	0.10	560	7	2	5000	RS80G561MDN1□□	FP-4R0RE561M-S8□□
		560	6.3×8	0.10	560	7	2	5000	RS80G561MCN1□□	FP-4R0RE561M-S8□□-H
		* 560	6.3×8	0.10	560	7	2	5000	RS80G561MDNASQ□□	FP-4R0RE561M-S8□□-5K
		* 560	6.3×8	0.10	560	7	2	5000	RS80G561MCNASQ□□	FP-4R0RE561M-S8□□-5KH
6.3 (0J)	7.2	330	6.3×8	0.10	519	8	2	5000	RS80J331MDN1□□	FP-6R3RE331M-S8□□
		330	6.3×8	0.10	519	8	2	5000	RS80J331MCN1□□	FP-6R3RE331M-S8□□-H
		* 330	6.3×8	0.10	519	8	2	5000	RS80J331MDNASQ□□	FP-6R3RE331M-S8□□-5K
		* 330	6.3×8	0.10	519	8	2	5000	RS80J331MCNASQ□□	FP-6R3RE331M-S8□□-5KH
		470	6.3×8	0.10	740	8	2	5000	RS80J471MDN1□□	FP-6R3RE471M-S8□□
		470	6.3×8	0.10	740	8	2	5000	RS80J471MCN1□□	FP-6R3RE471M-S8□□-H
		* 470	6.3×8	0.10	740	8	2	5000	RS80J471MDNASQ□□	FP-6R3RE471M-S8□□-5K
		* 470	6.3×8	0.10	740	8	2	5000	RS80J471MCNASQ□□	FP-6R3RE471M-S8□□-5KH
		560	6.3×8	0.10	882	8	2	5000	RS80J561MDN1□□	FP-6R3RE561M-S8□□
		560	6.3×8	0.10	882	8	2	5000	RS80J561MCN1□□	FP-6R3RE561M-S8□□-H
		* 560	6.3×8	0.10	882	8	2	5000	RS80J561MDNASQ□□	FP-6R3RE561M-S8□□-5K
		* 560	6.3×8	0.10	882	8	2	5000	RS80J561MCNASQ□□	FP-6R3RE561M-S8□□-5KH
		680	6.3×8	0.10	1071	8	2	4700	RS80J681MDN1□□	FP-6R3RE681M-S8□□
		680	6.3×8	0.10	1071	8	2	4700	RS80J681MCN1□□	FP-6R3RE681M-S8□□-H
		820	6.3×8	0.10	1291	8	2	4700	RS80J821MDN1□□	FP-6R3RE821M-S8□□
		820	6.3×8	0.10	1291	8	2	4700	RS80J821MCN1□□	FP-6R3RE821M-S8□□-H
16 (1C)	18.4	100	6.3×8	0.10	500	14	2	3800	RS81C101MDN1□□	FP-016RE101M-S8□□
		* 100	6.3×8	0.10	500	14	2	3800	RS81C101MDNASQ□□	FP-016RE101M-S8□□-5K
		* 100	6.3×8	0.10	500	14	2	3800	RS81C101MCNASQ□□	FP-016RE101M-S8□□-5KH
		270	6.3×8	0.10	1296	15	2	3800	RS81C271MDN1□□	FP-016RE271M-S8□□
		270	6.3×8	0.10	1296	15	2	3800	RS81C271MCN1□□	FP-016RE271M-S8□□-H
		* 270	6.3×8	0.10	1296	15	2	3800	RS81C271MDNASQ□□	FP-016RE271M-S8□□-5K
		* 270	6.3×8	0.10	1296	15	2	3800	RS81C271MCNASQ□□	FP-016RE271M-S8□□-5KH
		330	6.3×8	0.10	1584	12	2	4680	RS81C331MDN1□□	FP-016RE331M-S8□□
		330	6.3×8	0.10	1584	12	2	4680	RS81C331MCN1□□	FP-016RE331M-S8□□-H
		* 330	6.3×8	0.10	1584	12	2	4680	RS81C331MDNASQ□□	FP-016RE331M-S8□□-5K
		* 330	6.3×8	0.10	1584	12	2	4680	RS81C331MCNASQ□□	FP-016RE331M-S8□□-5KH
		25 (1E)	28.7	56	6.3×8	0.10	500	18	2	3500
* 56	6.3×8			0.10	500	18	2	3500	RS81E560MCNASQ□□	FP-025RE560M-S8□□-5KH
68	6.3×8			0.10	510	18	2	3500	RS81E680MCN1□□	FP-025RE680M-S8□□-H
* 68	6.3×8			0.10	510	18	2	3500	RS81E680MCNASQ□□	FP-025RE680M-S8□□-5KH
82	6.3×8			0.10	615	18	2	3500	RS81E820MCN1□□	FP-025RE820M-S8□□-H
* 82	6.3×8			0.10	615	18	2	3500	RS81E820MCNASQ□□	FP-025RE820M-S8□□-5KH
100	6.3×8			0.10	750	18	2	3500	RS81E101MCN1□□	FP-025RE101M-S8□□-H
* 100	6.3×8			0.10	750	18	2	3500	RS81E101MCNASQ□□	FP-025RE101M-S8□□-5KH

* : Load life 5000hours.

■ Frequency Characteristics (The frequency characteristics are typical and not a guaranteed value.)

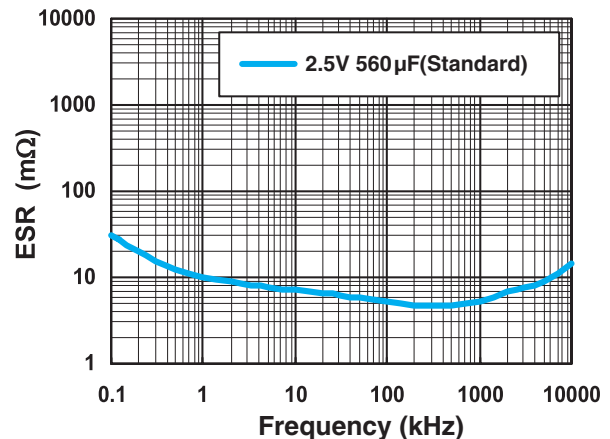
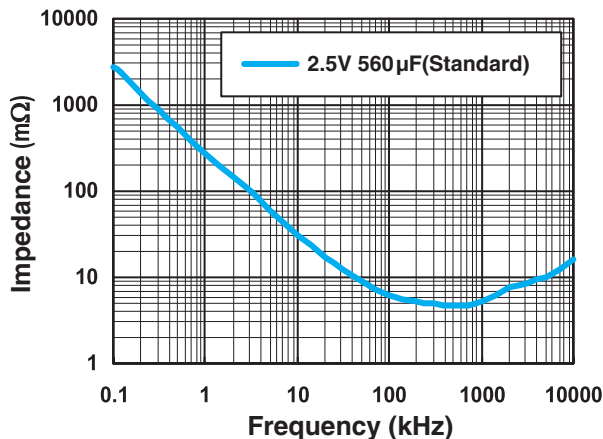

• For formed lead or taped product specifications and minimum order quantity, please refer to the Guidelines for Aluminum Electrolytic Capacitors.

RF8 Low ESR / ESL, Low Profile (φ5)



FPCAP

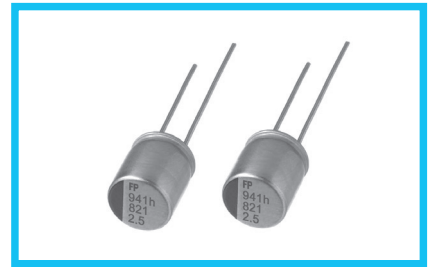

- Low ESR/ESL, High ripple current.
- Low Profile(Height 8mm).
- Load life of 2000 hours at 105°C.
- Radial lead type : Lead free flow soldering condition correspondence.
- Compliant to the RoHS directive (2011/65/EU,(EU)2015/863).

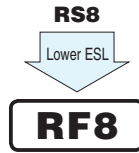

Specifications

Item	Performance Characteristics	
Category Temperature Range	-55 to +105°C	
Rated Voltage Range	2.5 to 6.3V	
Rated Capacitance Range	100 to 560μF	
Capacitance Tolerance	±20% at 120Hz, 20°C	
Tangent of loss angle (tan δ)	Less than or equal to the specified value at 120Hz, 20°C	
ESR (※1)	Less than or equal to the specified value at 100kHz, 20°C	
Leakage Current (※2)	Less than or equal to the specified value. After 2 minutes' application of rated voltage at 20°C	
Endurance	Test condition	105°C, rated voltage 2000Hrs.
	Capacitance change	Within ±20% of initial value before test
	tan δ	150% or less than the initial specified value
	ESR(※1)	150% or less than the initial specified value
	Leakage current (※2)	Less than or equal to the initial specified value

※1 ESR should be measured at both of the terminal ends closest where the terminals protrude through the plastic platform.

※2 Conditioning : If any doubt arises, measure the leakage current after the voltage treatment of applying DC rated voltage continuously to the capacitor for 120 minutes at 105°C.

Dimensions

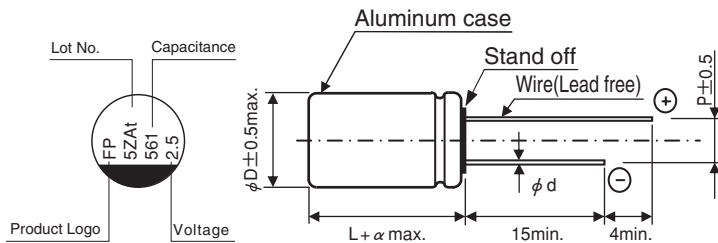

(mm)			
φD×L	φd	P	α
5×8	0.6	2.0	1.0

Type numbering system (Example : 2.5V 560μF) Nichicon part number

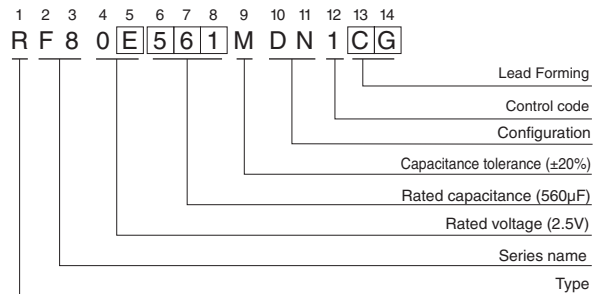

Frequency coefficient of rated ripple current

Frequency	120 Hz	1 kHz	10 kHz	100 kHz	300 kHz
Coefficient	0.10	0.45	0.50	1.00	1.00

FPCAP part number

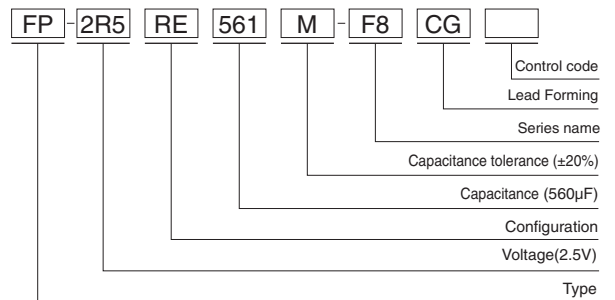

RF8

■ Dimensions

Rated Voltage (V) (code)	Surge Voltage (V)	Rated Capacitance (μF)	Case Size φD×L (mm)	tan δ	Leakage Current (μA) (at 20°C after 2 minutes)	ESR (mΩ) (20°C/100kHz)	ESL (Typ.) (nH, 40MHz)	Rated Ripple Current (mA rms) (105°C/100kHz)	NICHICON	FPCAP
2.5 (0E)	2.8	100	5×8	0.10	500	7	1.5	4200	RF80E101MDN1□□	FP-2R5RE101M-F8□□
		330	5×8	0.10	500	7	1.5	4200	RF80E331MDN1□□	FP-2R5RE331M-F8□□
		470	5×8	0.10	500	7	1.5	4200	RF80E471MDN1□□	FP-2R5RE471M-F8□□
		560	5×8	0.10	500	7	1.5	4200	RF80E561MDN1□□	FP-2R5RE561M-F8□□
4.0 (0G)	4.6	330	5×8	0.10	500	8	1.5	4000	RF80G331MDN1□□	FP-4R0RE331M-F8□□
6.3 (0J)	7.2	270	5×8	0.10	500	11	1.5	3700	RF80J271MDN1□□	FP-6R3RE271M-F8□□
		330	5×8	0.10	500	11	1.5	3700	RF80J331MDN1□□	FP-6R3RE331M-F8□□

■ Frequency Characteristics (The frequency characteristics are typical and not a guaranteed value.)

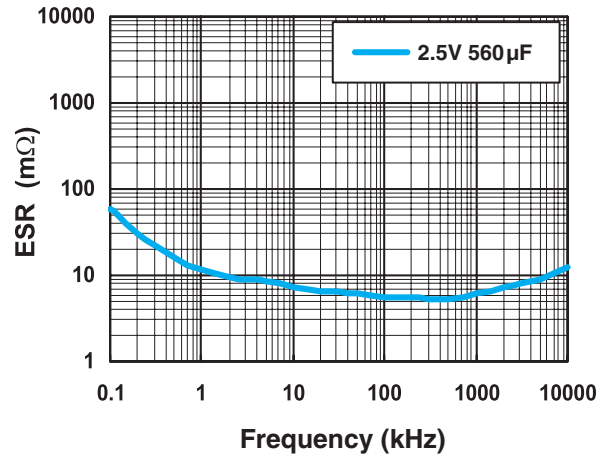
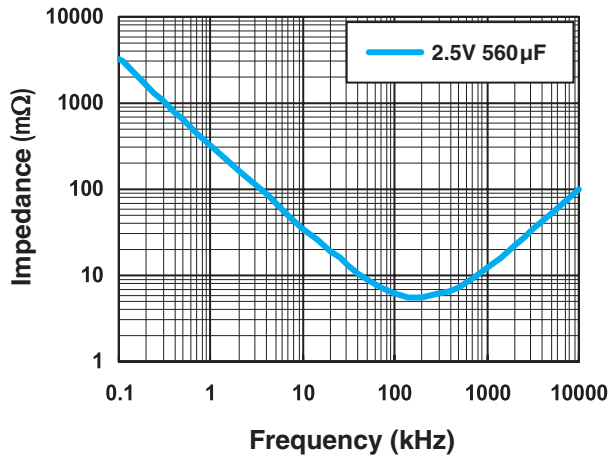

• For formed lead or taped product specifications and minimum order quantity, please refer to the Guidelines for Aluminum Electrolytic Capacitors.

RNU High Capacitance



FPCAP

- Low ESR, High Capacitance, High ripple current.
- Load life of 2000/5000 hours at 105°C.
- Radial lead type : Lead free flow soldering condition correspondence.
- Compliant to the RoHS directive (2011/65/EU,(EU)2015/863).

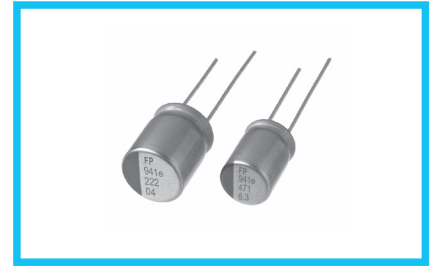
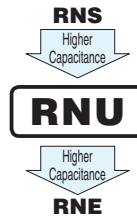

■ Specifications

Item	Performance Characteristics	
Category Temperature Range	-55 to +105°C	
Rated Voltage Range	2.5 to 63V	
Rated Capacitance Range	10 to 2700μF	
Capacitance Tolerance	±20% at 120Hz, 20°C	
Tangent of loss angle (tan δ)	Less than or equal to the specified value at 120Hz, 20°C	
ESR (※1)	Less than or equal to the specified value at 100kHz, 20°C	
Leakage Current (※2)	Less than or equal to the specified value. After 2 minutes' application of rated voltage at 20°C	
Endurance	Test condition	105°C, rated voltage 2000 / 5000Hrs.
	Capacitance change	Within ±20% of initial value before test
	tan δ	150% or less than the initial specified value
	ESR(※1)	150% or less than the initial specified value
	Leakage current (※2)	Less than or equal to the initial specified value

※1 ESR should be measured at both of the terminal ends closest to the capacitor body.

※2 Conditioning : If any doubt arises, measure the leakage current after the voltage treatment of applying DC rated voltage continuously to the capacitor for 120 minutes at 105°C.

■ Dimensions

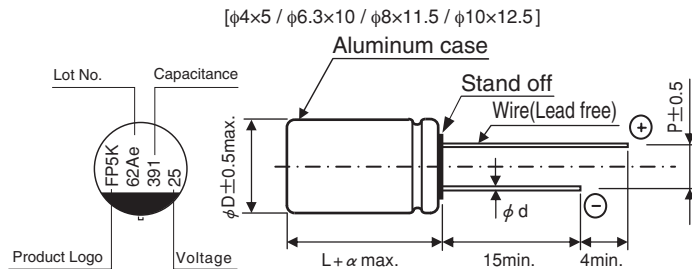

[φ4×5 / φ6.3×10 / φ8×11.5(-H or -5KH)]

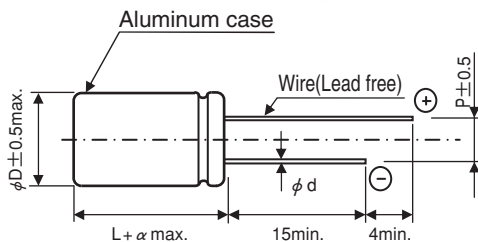

φD×L	φd	P	α
4×5	0.45	1.5	1.0
6.3×10	0.5	2.5	1.0
8×11.5	0.6	3.5	1.5
10×12.5	0.6	5.0	1.5

Type numbering system (Example : 25V 390μF)
Nichicon part number

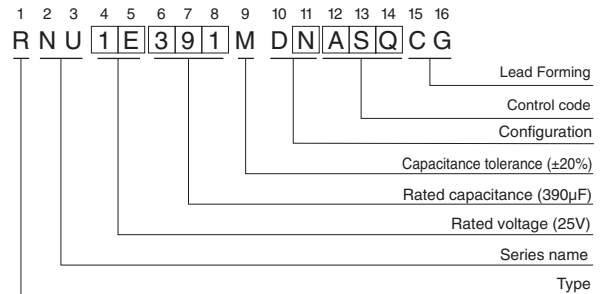

FPCAP part number

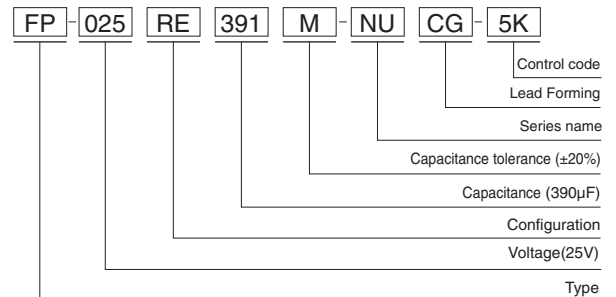

• Frequency coefficient of rated ripple current

Frequency	120 Hz	1 kHz	10 kHz	100 kHz	300 kHz
Coefficient	0.10	0.45	0.50	1.00	1.00

RNU

■ Dimensions

Rated Voltage (V) (code)	Surge Voltage (V)	Rated Capacitance (μF)	Case Size φD×L (mm)	tan δ	Leakage Current (μA) (at 20°C after 2 minutes)	ESR (mΩ) (20°C/100kHz)	Rated Ripple Current (mA rms) (105°C/100kHz)	NICHICON	FPCAP
2.5 (0E)	2.8	1500	8×11.5	0.08	937	7	4700	RNU0E152MDN1□□	FP-2R5RE152M-NU□□
		1500	8×11.5	0.08	937	7	4700	RNU0E152MCN1□□	FP-2R5RE152M-NU□□-H
		2700	10×12.5	0.08	1350	7	6100	RNU0E272MDN1□□	FP-2R5RE272M-NU□□
4.0 (0G)	4.6	820	8×11.5	0.08	656	7	5700	RNU0G821MDN1□□	FP-4R0RE821M-NU□□
		820	8×11.5	0.08	656	7	5700	RNU0G821MCN1□□	FP-4R0RE821M-NU□□-H
		1000	8×11.5	0.08	800	7	5700	RNU0G102MDN1□□	FP-4R0RE102M-NU□□
		1000	8×11.5	0.08	800	7	5700	RNU0G102MCN1□□	FP-4R0RE102M-NU□□-H
		1200	8×11.5	0.08	960	7	5700	RNU0G122MDN1□□	FP-4R0RE122M-NU□□
		1200	8×11.5	0.08	960	7	5700	RNU0G122MCN1□□	FP-4R0RE122M-NU□□-H
		1800	10×12.5	0.08	1440	7	6100	RNU0G182MDN1□□	FP-4R0RE182M-NU□□
		2200	10×12.5	0.08	1760	7	6100	RNU0G222MDN1□□	FP-4R0RE222M-NU□□
6.3 (0J)	7.2	220	6.3×10	0.08	277	20	3200	RNU0J221MDS1□□	FP-6R3RE221M-NU□□
		220	6.3×10	0.08	277	20	3200	RNU0J221MCS1□□	FP-6R3RE221M-NU□□-H
		470	8×11.5	0.08	592	7	5700	RNU0J471MDN1□□	FP-6R3RE471M-NU□□
		470	8×11.5	0.08	592	7	5700	RNU0J471MCN1□□	FP-6R3RE471M-NU□□-H
		680	8×11.5	0.08	856	7	5700	RNU0J681MDN1□□	FP-6R3RE681M-NU□□
		680	8×11.5	0.08	856	7	5700	RNU0J681MCN1□□	FP-6R3RE681M-NU□□-H
		820	8×11.5	0.08	1033	7	5700	RNU0J821MDN1□□	FP-6R3RE821M-NU□□
		820	8×11.5	0.08	1033	7	5700	RNU0J821MCN1□□	FP-6R3RE821M-NU□□-H
		1000	8×11.5	0.08	1260	7	5700	RNU0J102MDN1□□	FP-6R3RE102M-NU□□
		1000	8×11.5	0.08	1260	7	5700	RNU0J102MCN1□□	FP-6R3RE102M-NU□□-H
		1200	8×11.5	0.08	1512	9	6100	RNU0J122MDN1□□	FP-6R3RE122M-NU□□
		1200	8×11.5	0.08	1512	9	6100	RNU0J122MCN1□□	FP-6R3RE122M-NU□□-H
10 (1A)	11.5	10	4×5	0.12	300	220	700	RNU1A100MDS1□□	FP-010RE100M-NU□□
		10	4×5	0.12	300	220	700	RNU1A100MCS1□□	FP-010RE100M-NU□□-H
		* 10	4×5	0.12	300	220	700	RNU1A100MDSASQ□□	FP-010RE100M-NU□□-5K
		* 10	4×5	0.12	300	220	700	RNU1A100MCSASQ□□	FP-010RE100M-NU□□-5KH
		820	8×11.5	0.08	1640	10	5800	RNU1A821MDN1□□	FP-010RE821M-NU□□
		820	8×11.5	0.08	1640	10	5800	RNU1A821MCN1□□	FP-010RE821M-NU□□-H
		* 820	8×11.5	0.08	1640	10	5800	RNU1A821MDNASQ□□	FP-010RE821M-NU□□-5K
		* 820	8×11.5	0.08	1640	10	5800	RNU1A821MCNASQ□□	FP-010RE821M-NU□□-5KH
		1200	10×12.5	0.08	2400	9	6200	RNU1A122MDN1□□	FP-010RE122M-NU□□
16 (1C)	18.4	100	6.3×10	0.08	320	25	2820	RNU1C101MDS1□□	FP-016RE101M-NU□□
		100	6.3×10	0.08	320	25	2820	RNU1C101MCS1□□	FP-016RE101M-NU□□-H
		* 100	6.3×10	0.08	320	25	2820	RNU1C101MDSASQ□□	FP-016RE101M-NU□□-5K
		* 100	6.3×10	0.08	320	25	2820	RNU1C101MCSASQ□□	FP-016RE101M-NU□□-5KH
		180	8×11.5	0.08	576	8	5700	RNU1C181MDN1□□	FP-016RE181M-NU□□
		180	8×11.5	0.08	576	8	5700	RNU1C181MCN1□□	FP-016RE181M-NU□□-H
		270	8×11.5	0.08	864	8	5000	RNU1C271MDN1□□	FP-016RE271M-NU□□
		270	8×11.5	0.08	864	8	5000	RNU1C271MCN1□□	FP-016RE271M-NU□□-H
		* 270	8×11.5	0.08	864	8	5000	RNU1C271MDNASQ□□	FP-016RE271M-NU□□-5K
		* 270	8×11.5	0.08	864	8	5000	RNU1C271MCNASQ□□	FP-016RE271M-NU□□-5KH
		330	8×11.5	0.08	1056	8	6100	RNU1C331MDN1□□	FP-016RE331M-NU□□
		330	8×11.5	0.08	1056	8	6100	RNU1C331MCN1□□	FP-016RE331M-NU□□-H
		470	10×12.5	0.08	1504	10	6100	RNU1C471MDN1□□	FP-016RE471M-NU□□
		* 470	10×12.5	0.08	1504	10	6100	RNU1C471MDNASQ□□	FP-016RE471M-NU□□-5K
20 (1D)	23	390	8×11.5	0.12	1560	14	4970	RNU1D391MDN1□□	FP-020RE391M-NU□□
		390	8×11.5	0.12	1560	14	4970	RNU1D391MCN1□□	FP-020RE391M-NU□□-H
		* 390	8×11.5	0.12	1560	14	4970	RNU1D391MDNASQ□□	FP-020RE391M-NU□□-5K
		* 390	8×11.5	0.12	1560	14	4970	RNU1D391MCNASQ□□	FP-020RE391M-NU□□-5KH
		470	10×12.5	0.12	1880	12	5400	RNU1D471MDN1□□	FP-020RE471M-NU□□
		560	10×12.5	0.12	2240	12	5400	RNU1D561MDN1□□	FP-020RE561M-NU□□
		680	10×12.5	0.12	2720	12	5400	RNU1D681MDN1□□	FP-020RE681M-NU□□
		820	10×12.5	0.12	3280	12	5400	RNU1D821MDN1□□	FP-020RE821M-NU□□

* : Load life 5000hours.

RNU

■ Dimensions

Rated Voltage (V) (code)	Surge Voltage (V)	Rated Capacitance (μF)	Case Size φD×L (mm)	tan δ	Leakage Current (μA) (at 20°C after 2 minutes)	ESR (mΩ) (20°C/100kHz)	Rated Ripple Current (mA rms) (105°C/100kHz)	NICHICON	FPCAP
25 (1E)	28.7	33	8×11.5	0.12	412	24	3600	RNU1E330MDN1□□	FP-025RE330M-NU□□
		33	8×11.5	0.12	412	24	3600	RNU1E330MCN1□□	FP-025RE330M-NU□□-H
		47	8×11.5	0.12	587	24	3600	RNU1E470MDN1□□	FP-025RE470M-NU□□
		47	8×11.5	0.12	587	24	3600	RNU1E470MCN1□□	FP-025RE470M-NU□□-H
		68	8×11.5	0.12	850	24	3600	RNU1E680MDN1□□	FP-025RE680M-NU□□
		68	8×11.5	0.12	850	24	3600	RNU1E680MCN1□□	FP-025RE680M-NU□□-H
		180	8×11.5	0.12	900	16	4650	RNU1E181MDN1□□	FP-025RE181M-NU□□
		180	8×11.5	0.12	900	16	4650	RNU1E181MCN1□□	FP-025RE181M-NU□□-H
		220	8×11.5	0.12	1100	16	4650	RNU1E221MDN1□□	FP-025RE221M-NU□□
		220	8×11.5	0.12	1100	16	4650	RNU1E221MCN1□□	FP-025RE221M-NU□□-H
		*220	8×11.5	0.12	1100	16	4650	RNU1E221MDNASQ□□	FP-025RE221M-NU□□-5K
		*220	8×11.5	0.12	1100	16	4650	RNU1E221MCNASQ□□	FP-025RE221M-NU□□-5KH
		330	10×12.5	0.12	1650	14	5000	RNU1E331MDN1□□	FP-025RE331M-NU□□
		*330	10×12.5	0.12	1650	14	5000	RNU1E331MDNASQ□□	FP-025RE331M-NU□□-5K
390	10×12.5	0.12	1950	14	5000	RNU1E391MDN1□□	FP-025RE391M-NU□□		
*390	10×12.5	0.12	1950	14	5000	RNU1E391MDNASQ□□	FP-025RE391M-NU□□-5K		
470	10×12.5	0.12	2350	14	5000	RNU1E471MDN1□□	FP-025RE471M-NU□□		
35 (1V)	40.2	47	8×11.5	0.12	329	24	3600	RNU1V470MDN1□□	FP-035RE470M-NU□□
		47	8×11.5	0.12	329	24	3600	RNU1V470MCN1□□	FP-035RE470M-NU□□-H
		*82	8×11.5	0.12	574	20	4000	RNU1V820MDNASQ□□	FP-035RE820M-NU□□-5K
		*82	8×11.5	0.12	574	20	4000	RNU1V820MCNASQ□□	FP-035RE820M-NU□□-5KH
		*120	10×12.5	0.12	840	18	4400	RNU1V121MDNASQ□□	FP-035RE121M-NU□□-5K
		150	10×12.5	0.12	1050	20	3800	RNU1V151MDN1□□	FP-035RE151M-NU□□
50 (1H)	57.5	39	8×11.5	0.12	390	25	2400	RNU1H390MDN1□□	FP-050RE390M-NU□□
		39	8×11.5	0.12	390	25	2400	RNU1H390MCN1□□	FP-050RE390M-NU□□-H
		47	10×12.5	0.12	470	24	2700	RNU1H470MDN1□□	FP-050RE470M-NU□□
		68	10×12.5	0.12	680	24	2700	RNU1H680MDN1□□	FP-050RE680M-NU□□
63 (1J)	72.5	33	8×11.5	0.12	415	26	2300	RNU1J330MDN1□□	FP-063RE330M-NU□□
		33	8×11.5	0.12	415	26	2300	RNU1J330MCN1□□	FP-063RE330M-NU□□-H
		39	10×12.5	0.12	491	25	2600	RNU1J390MDN1□□	FP-063RE390M-NU□□
		47	10×12.5	0.12	592	25	2600	RNU1J470MDN1□□	FP-063RE470M-NU□□
		56	10×12.5	0.12	705	25	2600	RNU1J560MDN1□□	FP-063RE560M-NU□□

* : Load life 5000hours.

■ Frequency Characteristics (The frequency characteristics are typical and not a guaranteed value.)

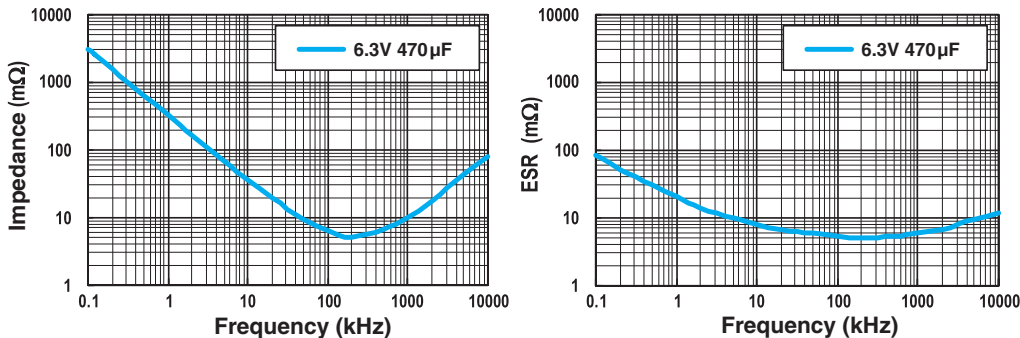

• For formed lead or taped product specifications and minimum order quantity, please refer to the Guidelines for Aluminum Electrolytic Capacitors.

RNE High Capacitance



FPCAP

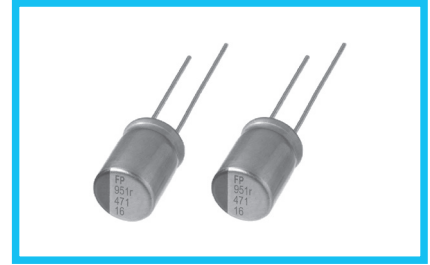

- Low ESR, High Capacitance, High ripple current.
- Load life of 2000/5000 hours at 105°C.
- Radial lead type : Lead free flow soldering condition correspondence.
- Compliant to the RoHS directive (2011/65/EU,(EU)2015/863).

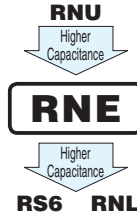

Specifications

Item	Performance Characteristics	
Category Temperature Range	-55 to +105°C	
Rated Voltage Range	2.5 to 25V	
Rated Capacitance Range	100 to 1500μF	
Capacitance Tolerance	±20% at 120Hz, 20°C	
Tangent of loss angle (tan δ)	Less than or equal to the specified value at 120Hz, 20°C	
ESR (※1)	Less than or equal to the specified value at 100kHz, 20°C	
Leakage Current (※2)	Less than or equal to the specified value. After 2 minutes' application of rated voltage at 20°C	
Endurance	Test condition	105°C, rated voltage 2000 / 5000Hrs.
	Capacitance change	Within ±20% of initial value before test
	tan δ	150% or less than the initial specified value
	ESR(※1)	150% or less than the initial specified value
	Leakage current (※2)	Less than or equal to the initial specified value

※1 ESR should be measured at both of the terminal ends closest to the capacitor body.

※2 Conditioning : If any doubt arises, measure the leakage current after the voltage treatment of applying DC rated voltage continuously to the capacitor for 120 minutes at 105°C.

Dimensions

[φ5×8 / φ5×10 / φ6.3×10 / φ8×6 / φ8×9 / φ8×11.5 / φ10×12.5]

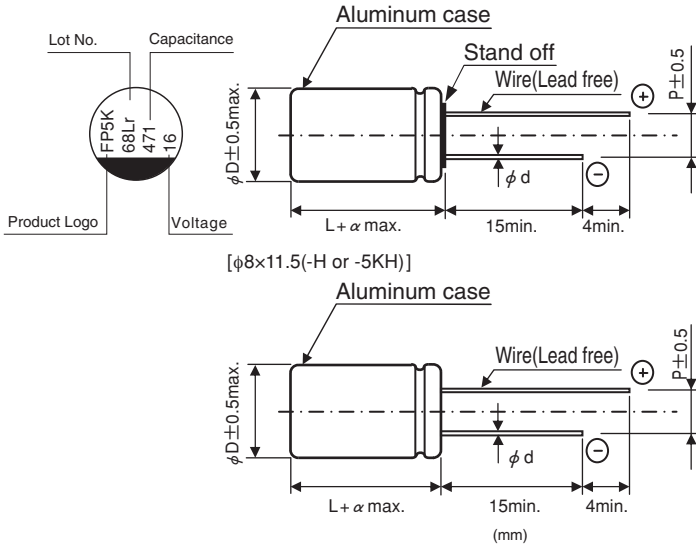

φD×L	φd	P	α
5×8	0.5	2.0	1.0
5×10	0.5	2.0	1.0
6.3×10	0.5	2.5	1.0
8×6	0.6	3.5	1.0
8×9	0.6	3.5	1.0
8×11.5	0.6	3.5	1.5
10×12.5	0.6	5.0	1.5

Type numbering system (Example : 16V 470μF) Nichicon part number

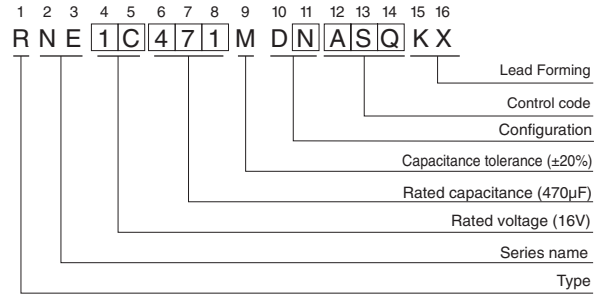

FPCAP part number

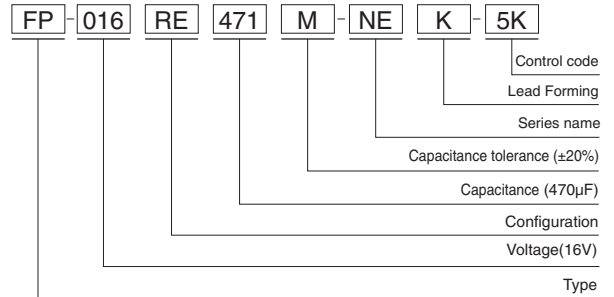

Frequency coefficient of rated ripple current

Frequency	120 Hz	1 kHz	10 kHz	100 kHz	300 kHz
Coefficient	0.10	0.45	0.50	1.00	1.00

● Dimension table in next page.

RNE

■ Dimensions

Rated Voltage (V) (code)	Surge Voltage (V)	Rated Capacitance (μF)	Case Size φD×L (mm)	tan δ	Leakage Current (μA) (at 20°C after 2 minutes)	ESR (mΩ) (20°C/100kHz)	Rated Ripple Current (mA rms) (105°C/100kHz)	NICHICON	FPCAP
2.5 (0E)	2.8	680	8×6	0.1	500	8	4900	RNE0E681MDN1 □□	FP-2R5RE681M-NE □□
		* 820	8×6	0.1	500	8	4900	RNE0E821MDNASQ □□	FP-2R5RE821M-NE □□ -5K
		* 820	8×6	0.1	500	8	4900	RNE0E821MCNASQ □□	FP-2R5RE821M-NE □□ -5KH
6.3 (0J)	7.2	270	5×8	0.1	500	12	3600	RNE0J271MDS1 □□	FP-6R3RE271M-NE □□
		330	5×8	0.1	500	10	3700	RNE0J331MDS1 □□	FP-6R3RE331M-NE □□
		330	5×8	0.1	500	10	3700	RNE0J331MCS1 □□	FP-6R3RE331M-NE □□ -H
		1200	8×9	0.08	1512	10	5700	RNE0J122MDN1 □□	FP-6R3RE122M-NE □□
		1500	8×11.5	0.12	1890	10	5400	RNE0J152MDN1 □□	FP-6R3RE152M-NE □□
		1500	8×11.5	0.12	1890	10	5400	RNE0J152MCN1 □□	FP-6R3RE152M-NE □□ -H
10 (1A)	11.5	220	6.3×10	0.08	440	30	2500	RNE1A221MDS1 □□	FP-010RE221M-NE □□
16 (1C)	18.4	100	5×10	0.08	320	35	2300	RNE1C101MDS1 □□	FP-016RE101M-NE □□
		220	8×6	0.1	500	13	4150	RNE1C221MDN1 □□	FP-016RE221M-NE □□
		270	6.3×10	0.08	864	15	3500	RNE1C271MCS1 □□	FP-016RE271M-NE □□ -H
		* 270	6.3×10	0.08	864	15	3500	RNE1C271MCSASQ □□	FP-016RE271M-NE □□ -5KH
		330	6.3×10	0.08	1056	15	3500	RNE1C331MCS1 □□	FP-016RE331M-NE □□ -H
		* 330	6.3×10	0.08	1056	15	3500	RNE1C331MCSASQ □□	FP-016RE331M-NE □□ -5KH
		390	6.3×10	0.08	1248	15	3500	RNE1C391MCS1 □□	FP-016RE391M-NE □□ -H
		* 390	6.3×10	0.08	1248	15	3500	RNE1C391MCSASQ □□	FP-016RE391M-NE □□ -5KH
		470	6.3×10	0.08	1504	15	3500	RNE1C471MCS6 □□	FP-016RE471M-NE □□ -H-DS
		* 470	6.3×10	0.08	1504	15	3500	RNE1C471MCSBSQ □□	FP-016RE471M-NE □□ -5KH-DS
		470	8×11.5	0.08	1504	10	5400	RNE1C471MDN1 □□	FP-016RE471M-NE □□
		470	8×11.5	0.08	1504	10	5400	RNE1C471MCN1 □□	FP-016RE471M-NE □□ -H
		* 470	8×11.5	0.08	1504	10	5400	RNE1C471MDNASQ □□	FP-016RE471M-NE □□ -5K
		* 470	8×11.5	0.08	1504	10	5400	RNE1C471MCNASQ □□	FP-016RE471M-NE □□ -5KH
		560	8×11.5	0.08	1792	14	5000	RNE1C561MDN1 □□	FP-016RE561M-NE □□
		560	8×11.5	0.08	1792	14	5000	RNE1C561MCN1 □□	FP-016RE561M-NE □□ -H
		* 560	8×11.5	0.08	1792	14	5000	RNE1C561MDNASQ □□	FP-016RE561M-NE □□ -5K
		* 560	8×11.5	0.08	1792	14	5000	RNE1C561MCNASQ □□	FP-016RE561M-NE □□ -5KH
		680	8×11.5	0.08	2176	10	5230	RNE1C681MCN1 □□	FP-016RE681M-NE □□ -H
		* 680	8×11.5	0.08	2176	10	5230	RNE1C681MCNASQ □□	FP-016RE681M-NE □□ -5KH
820	10×12.5	0.08	2624	11	5600	RNE1C821MDN1 □□	FP-016RE821M-NE □□		
* 820	10×12.5	0.08	2624	11	5600	RNE1C821MDNASQ □□	FP-016RE821M-NE □□ -5K		
1000	10×12.5	0.08	3200	10	6100	RNE1C102MDN1 □□	FP-016RE102M-NE □□		
* 1000	10×12.5	0.08	3200	10	6100	RNE1C102MDNASQ □□	FP-016RE102M-NE □□ -5K		
25 (1E)	28.7	* 560	10×12.5	0.08	2800	20	3100	RNE1E561MDNASQ □□	FP-025RE561M-NE □□ -5K

* : Load life 5000hours.

■ Frequency Characteristics (The frequency characteristics are typical and not a guaranteed value.)

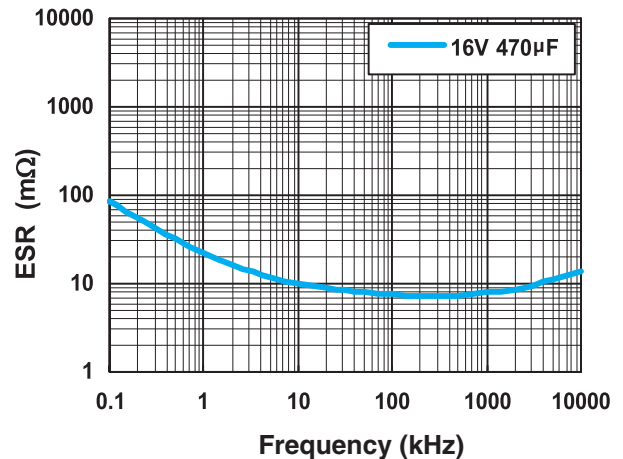
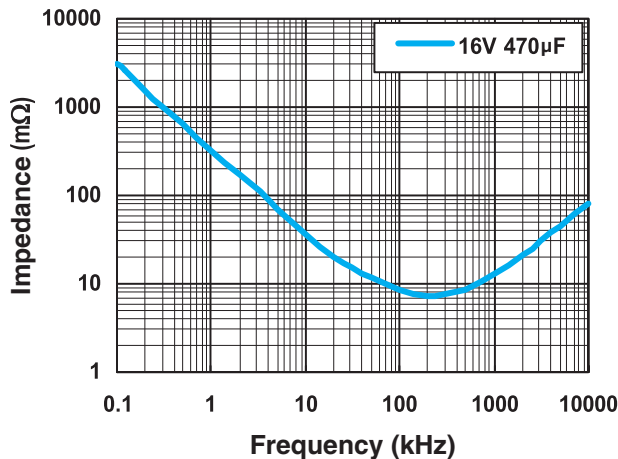

• For formed lead or taped product specifications and minimum order quantity, please refer to the Guidelines for Aluminum Electrolytic Capacitors.

RNL Large Sized, High Capacitance



FPCAP Expanded

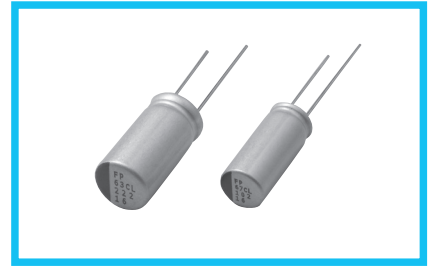

- Low ESR, High Capacitance, High ripple current.
- Large Sized.
- Load life of 2000 / 5000 hours at 105°C.
- Radial lead type : Lead free flow soldering condition correspondence.
- Compliant to the RoHS directive (2011/65/EU,(EU)2015/863).



■ Specifications

Item	Performance Characteristics	
Category Temperature Range	-55 to +105°C	
Rated Voltage Range	16 to 25V	
Rated Capacitance Range	270 to 2400μF	
Capacitance Tolerance	±20% at 120Hz, 20°C	
Tangent of loss angle (tan δ)	Less than or equal to the specified value at 120Hz, 20°C	
ESR (*1)	Less than or equal to the specified value at 100kHz, 20°C	
Leakage Current (*2)	Less than or equal to the specified value. After 2 minutes' application of rated voltage at 20°C	
Endurance	Test condition	105°C, rated voltage 2000 / 5000Hrs.
	Capacitance change	Within ±20% of initial value before test
	tan δ	150% or less than the initial specified value
	ESR(*1)	150% or less than the initial specified value
	Leakage current (*2)	Less than or equal to the initial specified value

*1 ESR should be measured at both of the terminal ends closest to the capacitor body.

*2 Conditioning : If any doubt arises, measure the leakage current after the voltage treatment of applying DC rated voltage continuously to the capacitor for 120 minutes at 105°C.

■ Dimensions

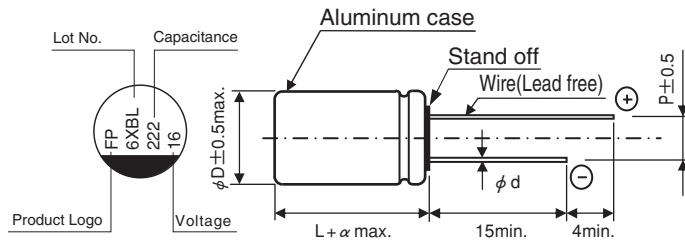

(mm)

φD×L	φd	P	α
φ8×16L	0.6	3.5	1.5
φ8×20L	0.6	3.5	1.5
φ10×16L	0.6	5.0	1.5
φ10×20L	0.6	5.0	1.5

● Frequency coefficient of rated ripple current

Frequency	120 Hz	1 kHz	10 kHz	100 kHz	300 kHz
Coefficient	0.10	0.45	0.50	1.00	1.00

Type numbering system (Example : 16V 2200μF)
Nichicon part number

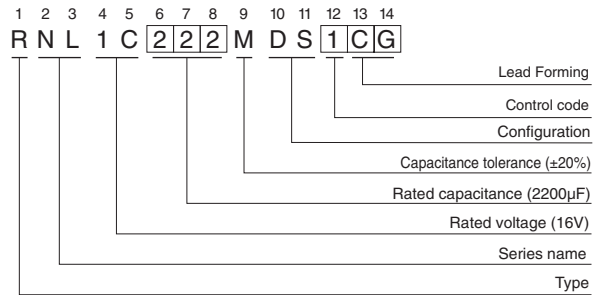

FPCAP part number

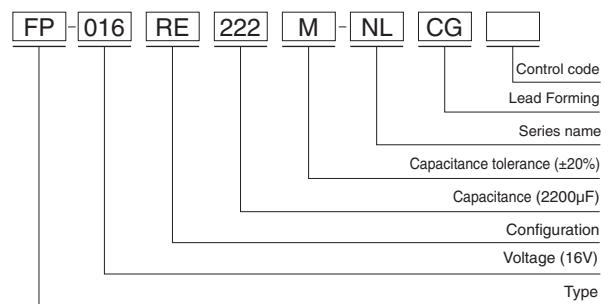

● Dimension table in next page.

RNL

■ Dimensions

Rated Voltage (V) (code)	Surge Voltage (V)	Rated Capacitance (μF)	Case Size φD×L (mm)	tan δ	Leakage Current (μA) (at 20°C after 2 minutes)	ESR (mΩ) (20°C/100kHz)	Rated Ripple Current (mA rms) (105°C/100kHz)	NICHICON	FFPCAP
16 (1C)	18.4	680	8×16	0.12	1088	8	7000	RNL1C681MDS1□□	FP-016RE681M-NL□□
		820	▲ 8×16	0.12	1312	8	7000	RNL1C821MDS6□□	FP-016RE821M-NL□□-DS
		* 820	8×16	0.12	1312	8	7000	RNL1C821MDSBSQ□□	FP-016RE821M-NL□□-5K-DS
		820	8×20	0.12	1312	8	7500	RNL1C821MDS1□□	FP-016RE821M-NL□□
		* 820	8×20	0.12	1312	8	7500	RNL1C821MDSASQ□□	FP-016RE821M-NL□□-5K
		1000	8×20	0.12	1600	8	7500	RNL1C102MDS1□□	FP-016RE102M-NL□□
		* 1000	8×20	0.12	1600	8	7500	RNL1C102MDSASQ□□	FP-016RE102M-NL□□-5K
		1000	10×16	0.12	1600	8	7700	RNL1C102MDS4□□	FP-016RE102M-NL□□-MS
		* 1000	10×16	0.12	1600	8	7700	RNL1C102MDSBSQ□□	FP-016RE102M-NL□□-5K-MS
		1200	8×20	0.12	1920	8	7500	RNL1C122MDS1□□	FP-016RE122M-NL□□
		* 1200	8×20	0.12	1920	8	7500	RNL1C122MDSASQ□□	FP-016RE122M-NL□□-5K
		1200	10×16	0.12	1920	8	7700	RNL1C122MDS4□□	FP-016RE122M-NL□□-MS
		* 1200	10×16	0.12	1920	8	7700	RNL1C122MDSBSQ□□	FP-016RE122M-NL□□-5K-MS
		1500	▲ 8×20	0.12	2400	8	7500	RNL1C152MDS6□□	FP-016RE152M-NL□□-DS
		1500	10×16	0.12	2400	8	7700	RNL1C152MDS4□□	FP-016RE152M-NL□□-MS
		* 1500	10×16	0.12	2400	8	7700	RNL1C152MDSBSQ□□	FP-016RE152M-NL□□-5K-MS
		1500	10×20	0.12	2400	8	8100	RNL1C152MDS1□□	FP-016RE152M-NL□□
		* 1500	10×20	0.12	2400	8	8100	RNL1C152MDSASQ□□	FP-016RE152M-NL□□-5K
		1800	10×16	0.12	2880	8	7700	RNL1C182MDS4□□	FP-016RE182M-NL□□-MS
		* 1800	10×16	0.12	2880	8	7700	RNL1C182MDSBSQ□□	FP-016RE182M-NL□□-5K-MS
		1800	10×20	0.12	2880	8	8100	RNL1C182MDS1□□	FP-016RE182M-NL□□
		* 1800	10×20	0.12	2880	8	8100	RNL1C182MDSASQ□□	FP-016RE182M-NL□□-5K
		2200	10×20	0.12	3520	8	8100	RNL1C222MDS1□□	FP-016RE222M-NL□□
		* 2200	10×20	0.12	3520	8	8100	RNL1C222MDSASQ□□	FP-016RE222M-NL□□-5K
2400	10×20	0.12	3840	8	8100	RNL1C242MDS1□□	FP-016RE242M-NL□□		
* 2400	10×20	0.12	3840	8	8100	RNL1C242MDSASQ□□	FP-016RE242M-NL□□-5K		
25 (1E)	28.7	270	8×16	0.12	675	10	5800	RNL1E271MDS1□□	FP-025RE271M-NL□□
		330	8×16	0.12	825	10	5800	RNL1E331MDS1□□	FP-025RE331M-NL□□
		390	8×16	0.12	975	10	5800	RNL1E391MDS1□□	FP-025RE391M-NL□□
		470	8×16	0.12	1175	10	5800	RNL1E471MDS1□□	FP-025RE471M-NL□□
		560	8×16	0.12	1400	10	5800	RNL1E561MDS1□□	FP-025RE561M-NL□□
		560	10×16	0.12	1400	10	5800	RNL1E561MDS4□□	FP-025RE561M-NL□□-MS
		* 560	10×16	0.12	1400	10	5800	RNL1E561MDSBSQ□□	FP-025RE561M-NL□□-5K-MS
		680	10×16	0.12	1700	10	5800	RNL1E681MDS4□□	FP-025RE681M-NL□□-MS
		* 680	10×16	0.12	1700	10	5800	RNL1E681MDSBSQ□□	FP-025RE681M-NL□□-5K-MS
		680	10×20	0.12	1700	10	8100	RNL1E681MDS9□□	FP-025RE681M-NL□□-US
		* 680	10×20	0.12	1700	10	8100	RNL1E681MDSCSQ□□	FP-025RE681M-NL□□-5K-US
		820	10×16	0.12	2050	10	5800	RNL1E821MDS4□□	FP-025RE821M-NL□□-MS
		* 820	10×16	0.12	2050	10	5800	RNL1E821MDSBSQ□□	FP-025RE821M-NL□□-5K-MS
		820	10×20	0.12	2050	10	8100	RNL1E821MDS1□□	FP-025RE821M-NL□□
		* 820	10×20	0.12	2050	10	8100	RNL1E821MDSASQ□□	FP-025RE821M-NL□□-5K
		1000	10×16	0.12	2500	10	5800	RNL1E102MDS4□□	FP-025RE102M-NL□□-MS
		* 1000	10×16	0.12	2500	10	5800	RNL1E102MDSBSQ□□	FP-025RE102M-NL□□-5K-MS
		1000	10×20	0.12	2500	10	8100	RNL1E102MDS1□□	FP-025RE102M-NL□□
		* 1000	10×20	0.12	2500	10	8100	RNL1E102MDSASQ□□	FP-025RE102M-NL□□-5K
		1200	10×20	0.12	3000	10	8100	RNL1E122MDS1□□	FP-025RE122M-NL□□
* 1200	10×20	0.12	3000	10	8100	RNL1E122MDSASQ□□	FP-025RE122M-NL□□-5K		

Blue : New product (as of October 2023)

* : Load life 5000hours.

▲ " In this case, [6] will be put at 12th digit of type numbering system

■ Frequency Characteristics (The frequency characteristics are typical and not a guaranteed value.)

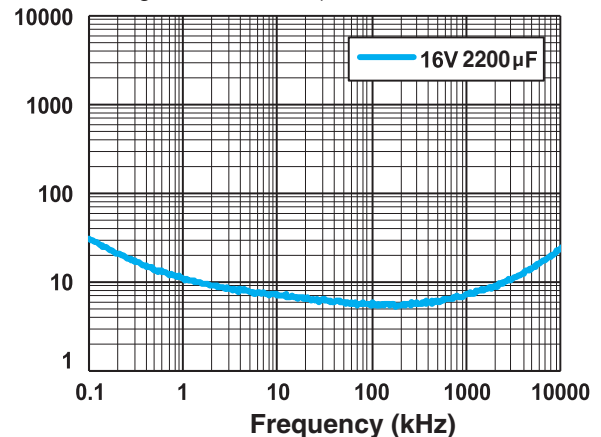
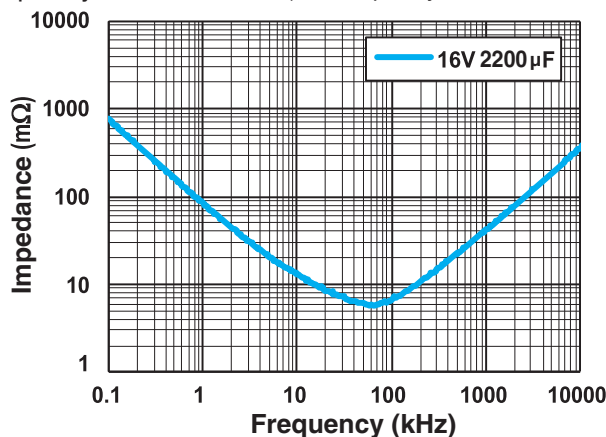

• For formed lead or taped product specifications and minimum order quantity, please refer to the Guidelines for Aluminum Electrolytic Capacitors.

RS6 Miniature Sized, High Capacitance



FPCAP

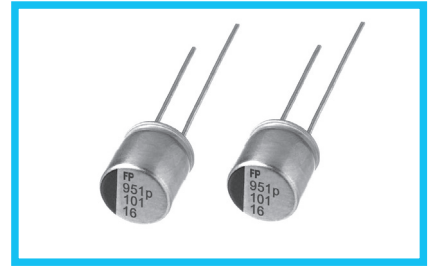

- Low ESR, High Capacitance, High ripple current.
- Miniature Sized.
- Load life of 2000 / 5000 hours at 105°C.
- Radial lead type : Lead free flow soldering condition correspondence.
- Compliant to the RoHS directive (2011/65/EU,(EU)2015/863).



Specifications

Item	Performance Characteristics	
Category Temperature Range	-55 to +105°C	
Rated Voltage Range	2.5 to 25V	
Rated Capacitance Range	33 to 560μF	
Capacitance Tolerance	±20% at 120Hz, 20°C	
Tangent of loss angle (tan δ)	Less than or equal to the specified value at 120Hz, 20°C	
ESR (※1)	Less than or equal to the specified value at 100kHz, 20°C	
Leakage Current (※2)	Less than or equal to the specified value. After 2 minutes' application of rated voltage at 20°C	
Endurance	Test condition	105°C, rated voltage 2000 / 5000Hrs.
	Capacitance change	Within ±20% of initial value before test
	tan δ	150% or less than the initial specified value
	ESR(※1)	150% or less than the initial specified value
	Leakage current (※2)	Less than or equal to the initial specified value

※1 ESR should be measured at both of the terminal ends closest to the capacitor body.

※2 Conditioning : If any doubt arises, measure the leakage current after the voltage treatment of applying DC rated voltage continuously to the capacitor for 120 minutes at 105°C.

Dimensions

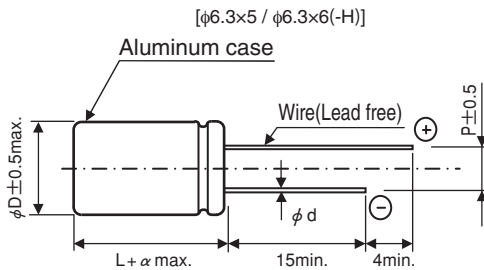
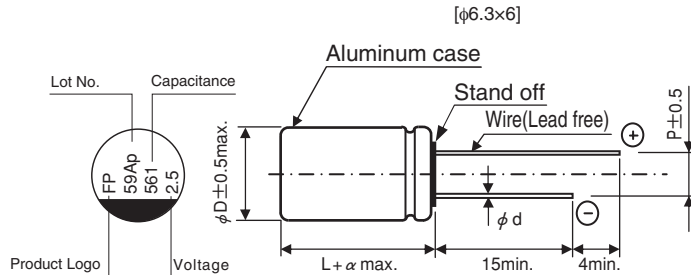

(mm)			
φD×L	φd	P	α
6.3×5	0.5	2.5	1.0
6.3×6	0.45	2.5	1.0

Frequency coefficient of rated ripple current

Frequency	120 Hz	1 kHz	10 kHz	100 kHz	300 kHz
Coefficient	0.10	0.45	0.50	1.00	1.00

Type numbering system (Example : 2.5V 560μF) Nichicon part number

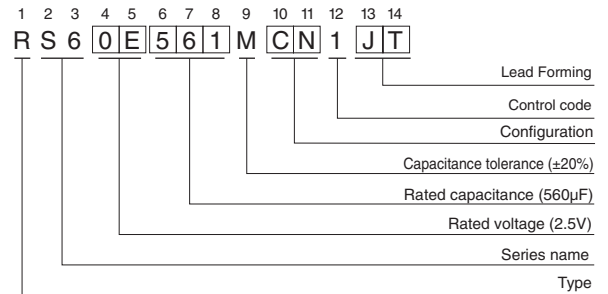

FPCAP part number

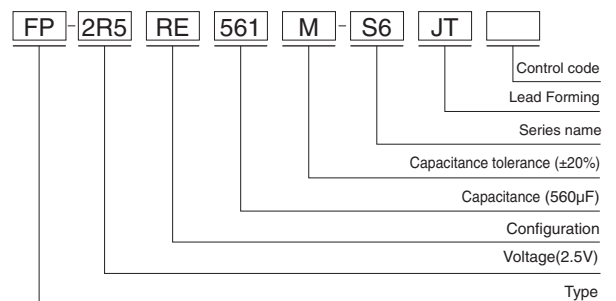

RS6

■ Dimensions

Rated Voltage (V) (code)	Surge Voltage (V)	Rated Capacitance (μF)	Case Size φD×L (mm)	tan δ	Leakage Current (μA) (at 20°C after 2 minutes)	ESR (mΩ) (20°C/100kHz)	Rated Ripple Current (mA rms) (105°C/100kHz)	NICHICON	FPCAP
2.5 (0E)	2.8	390	6.3×5	0.10	500	12	3500	RS60E391MCN1 □□	FP-2R5RE391M-S6 □□
		560	6.3×5	0.12	700	13	3600	RS60E561MCN1 □□	FP-2R5RE561M-S6 □□
		*560	6.3×5	0.12	700	13	3600	RS60E561MCNASQ □□	FP-2R5RE561M-S6 □□ -5K
6.3 (0J)	7.2	220	6.3×5	0.12	500	15	3200	RS60J221MCN1 □□	FP-6R3RE221M-S6 □□
10 (1A)	11.5	150	6.3×5	0.10	450	25	2500	RS61A151MCN1 □□	FP-010RE151M-S6 □□
16 (1C)	18.4	100	6.3×6	0.10	500	24	2490	RS61C101MDS1 □□	FP-016RE101M-S6 □□
		100	6.3×6	0.10	500	24	2490	RS61C101MCS1 □□	FP-016RE101M-S6 □□ -H
		180	6.3×5	0.10	576	20	3200	RS61C181MCN1 □□	FP-016RE181M-S6 □□
25 (1E)	28.7	33	6.3×5	0.10	165	60	1700	RS61E330MCN1 □□	FP-025RE330M-S6 □□
		47	6.3×5	0.10	235	30	2800	RS61E470MCN1 □□	FP-025RE470M-S6 □□
		56	6.3×5	0.10	280	30	2800	RS61E560MCN1 □□	FP-025RE560M-S6 □□

* : Load life 5000hours.

■ Frequency Characteristics (The frequency characteristics are typical and not a guaranteed value.)

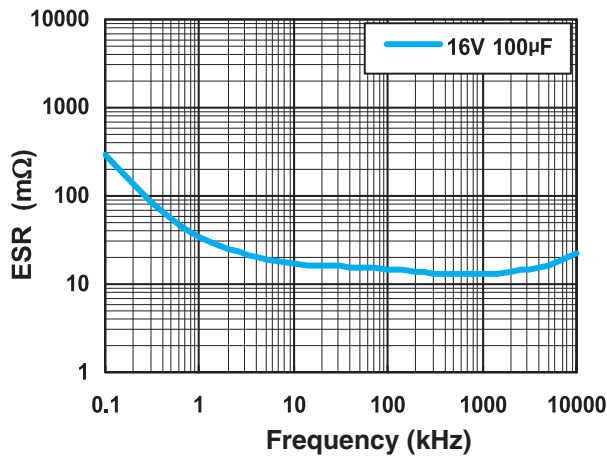
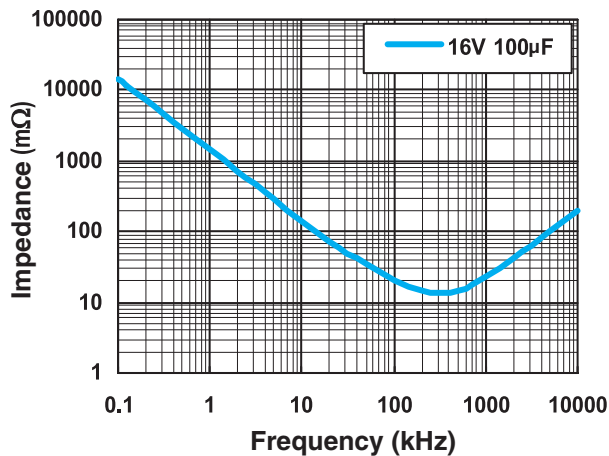

• For formed lead or taped product specifications and minimum order quantity, please refer to the Guidelines for Aluminum Electrolytic Capacitors.

RHT High Temperature(125°C)



FPCAP

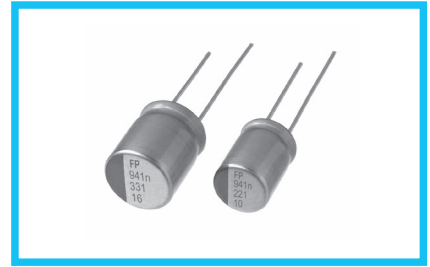

- Low ESR, High Capacitance, High ripple current.
- Load life of 1000 hours at 125°C.
- Radial lead type : Lead free flow soldering condition correspondence.
- Compliant to the RoHS directive (2011/65/EU,(EU)2015/863).

■ Specifications

Item	Performance Characteristics	
Category Temperature Range	-55 to +125°C	
Rated Voltage Range	6.3 to 35V	
Rated Capacitance Range	100 to 1000μF	
Capacitance Tolerance	±20% at 120Hz, 20°C	
Tangent of loss angle (tan δ)	Less than or equal to the specified value at 120Hz, 20°C	
ESR (※1)	Less than or equal to the specified value at 100kHz, 20°C	
Leakage Current (※2)	Less than or equal to the specified value. After 2 minutes' application of rated voltage at 20°C	
Endurance	Test condition	125°C, rated voltage 1000Hrs.
	Capacitance change	Within ±20% of initial value before test
	tan δ	200% or less than the initial specified value
	ESR(※1)	200% or less than the initial specified value
	Leakage current (※2)	Less than or equal to the initial specified value

※1 ESR should be measured at both of the terminal ends closest to the capacitor body.

※2 Conditioning : If any doubt arises, measure the leakage current after the voltage treatment of applying DC rated voltage continuously to the capacitor for 120 minutes at 105°C.

■ Dimensions

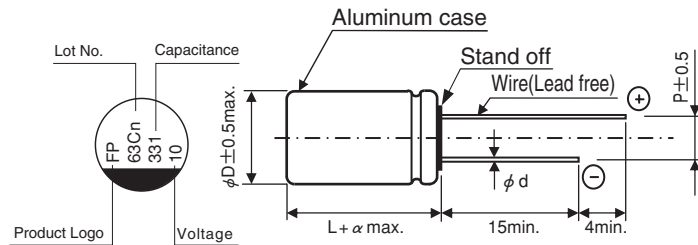

φD×L	φd	P	α
8×11.5	0.6	3.5	1.5
10×12.5	0.6	5.0	1.5

Type numbering system (Example : 10V 330μF)
Nichicon part number

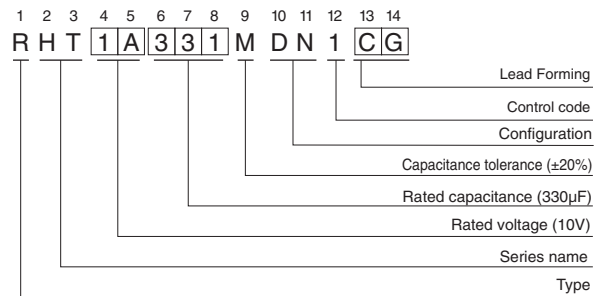

● Frequency coefficient of rated ripple current

Frequency	120 Hz	1 kHz	10 kHz	100 kHz	300 kHz
Coefficient	0.10	0.45	0.50	1.00	1.00

FPCAP part number

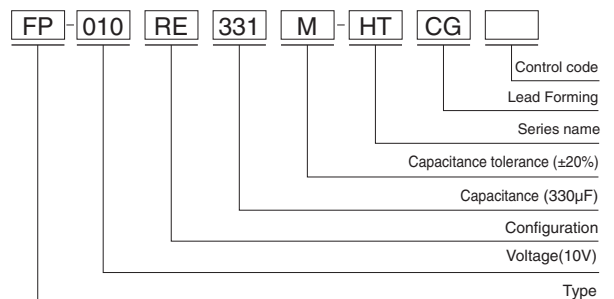

RHT

■ Dimensions

Rated Voltage (V) (code)	Surge Voltage (V)	Rated Capacitance (μF)	Case Size φD×L (mm)	tan δ	Leakage Current (μA) (at 20°C after 2 minutes)	ESR (mΩ) (20°C/100kHz)	Rated Ripple Current (mA)(105°C/100kHz)		NICHICON	FPCAP
							≤105°C *	105°C < ≤125°C *		
6.3 (0J)	7.2	680	10×12.5	0.12	856	12	5450	1740	RHT0J681MDN1□□	FP-6R3RE681M-HT□□
		820	10×12.5	0.12	1033	12	5450	1740	RHT0J821MDN1□□	FP-6R3RE821M-HT□□
		1000	8×11.5	0.12	1260	10	5200	1600	RHT0J102MDN1□□	FP-6R3RE102M-HT□□
10 (1A)	11.5	220	8×11.5	0.12	440	17	3950	1260	RHT1A221MDN1□□	FP-010RE221M-HT□□
		330	8×11.5	0.12	660	17	3950	1260	RHT1A331MDN1□□	FP-010RE331M-HT□□
		390	8×11.5	0.12	780	16	3950	1260	RHT1A391MDN1□□	FP-010RE391M-HT□□
		560	10×12.5	0.12	1120	13	5250	1680	RHT1A561MDN1□□	FP-010RE561M-HT□□
16 (1C)	18.4	270	10×12.5	0.12	864	16	4750	1520	RHT1C271MDN1□□	FP-016RE271M-HT□□
		330	10×12.5	0.12	1056	16	4750	1520	RHT1C331MDN1□□	FP-016RE331M-HT□□
		470	10×12.5	0.12	1504	16	4750	1520	RHT1C471MDN1□□	FP-016RE471M-HT□□
20 (1D)	23.0	150	10×12.5	0.12	600	20	4350	1390	RHT1D151MDN1□□	FP-020RE151M-HT□□
35 (1V)	40.2	100	10×12.5	0.12	700	25	3250	1040	RHT1V101MDN1□□	FP-035RE101M-HT□□

* : At ambient temperature

■ Frequency Characteristics (The frequency characteristics are typical and not a guaranteed value.)

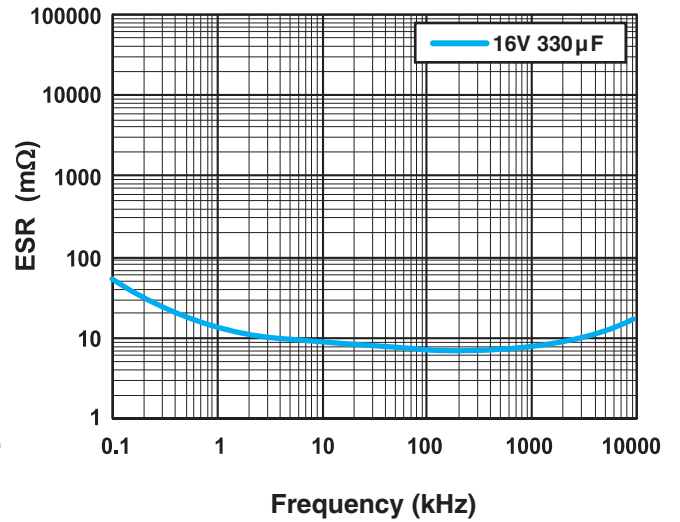
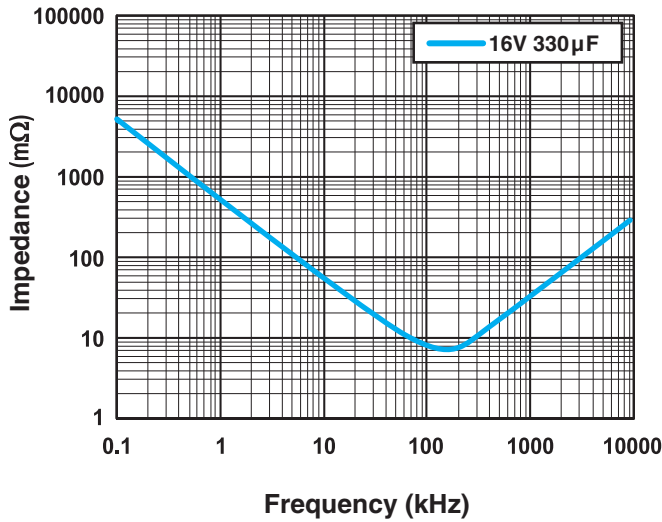

• For formed lead or taped product specifications and minimum order quantity, please refer to the Guidelines for Aluminum Electrolytic Capacitors.